

Parts List

Roof carrier (front)	Right base (front)	Left base (front)
Roof carrier (rear)	Right base (rear)	Left base (rear)
Hex wrench	Key plate (4)	Special nuts (8)
Socket bolts (8)	Plain washers (8)	Caps (4)
Front cushion (right)	Front cushion (left)	Rear cushion (right)

Rear cushion (left)

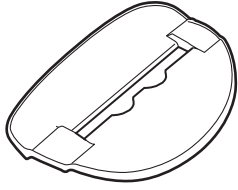

Tools and Supplies Required

- Plastic spatula
- Felt- tip pen
- Utility knife

Before You Begin

Customer Information

- Be sure that the area to be covered is clean and has been waxed with high quality paste wax.
- Be extremely careful not to damage the roof and other finished surfaces of the body.
- If you installed the carrier clamps, see Installation Instructions "CARRIER CLAMP".

Installation

1. Pull up the right and left roof moldings in the center, release the six retaining clips and remove the roof moldings.
 - Hold the right and left roof moldings in the center and remove them by pulling them up and outward.
 - Take care not to damage the retaining clips.

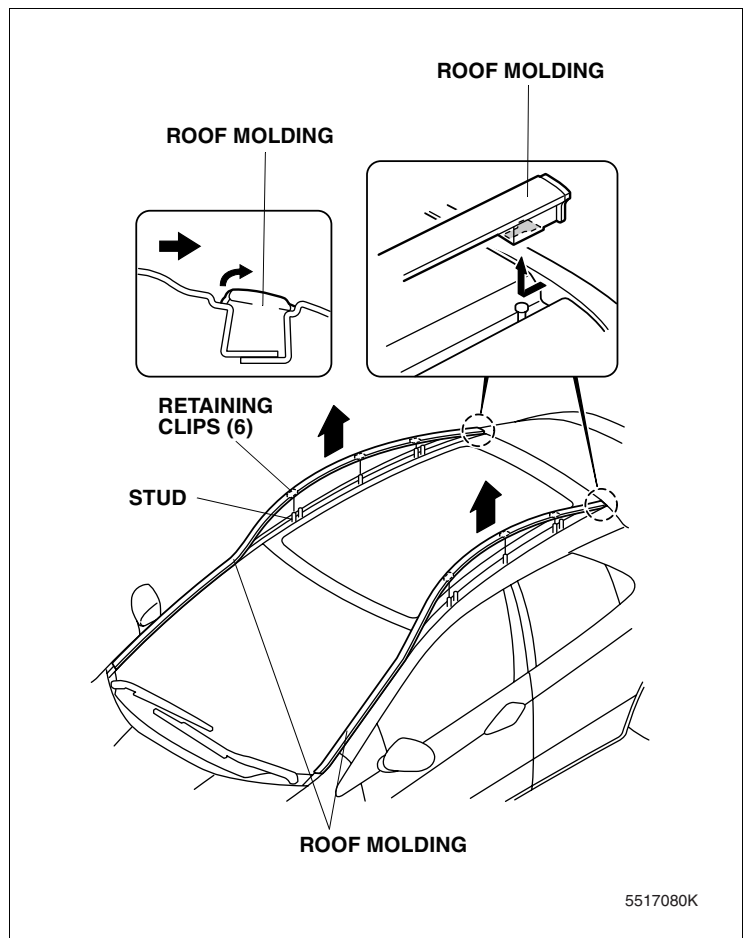

2. Using a plastic spatula, release the ten retaining clips of the right and left roof moldings at the front windshield.

- Release the retaining clips one by one. Start with the clip on the top of the vehicle and go to the lower part of the vehicle. To remove the roof molding, pull it up and outward by holding it in the center.
- Turn up the roof molding from the front windshield, insert a plastic spatula under side the roof molding and push the tab of each retaining clip as shown to release them.
- Release the retaining clips with care not to damage the front windshield.

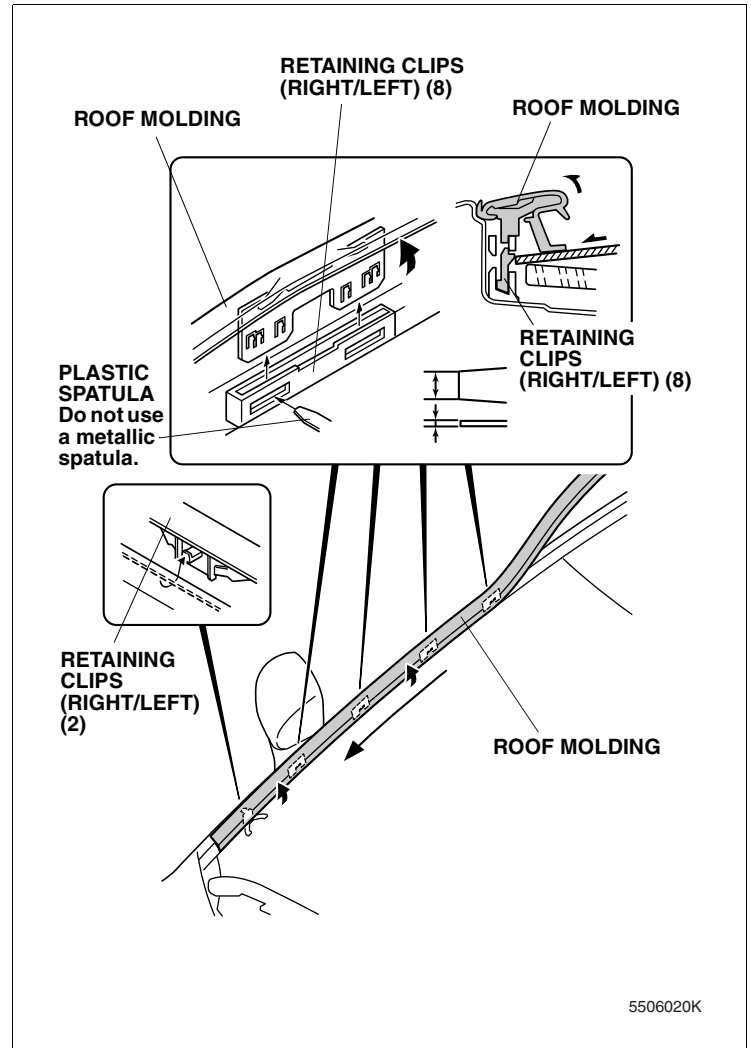

3. Measure the right / left roof molding from its rear end in the areas shown to make marks with a felt-tip pen.

- Take care not to confuse the rear end with the front end of the right / left roof molding.

4. Cut off at the marks on the right / left roof molding.

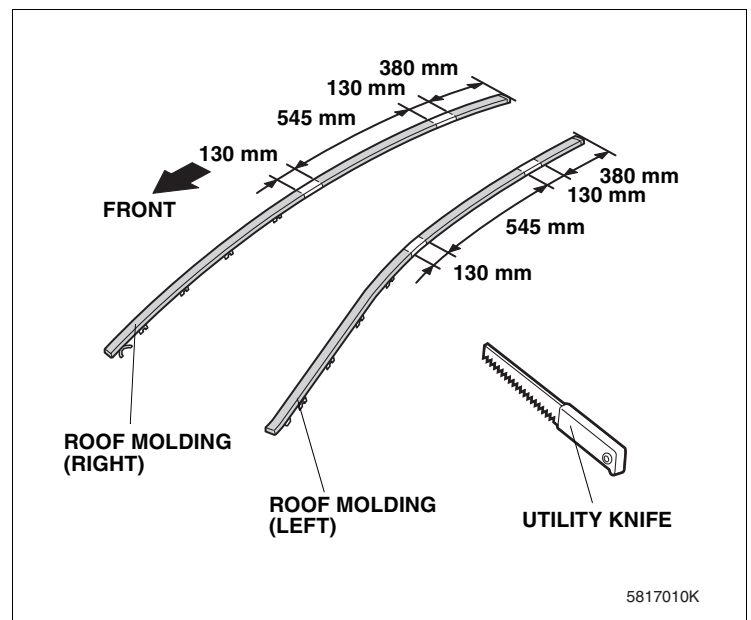

5. Turn up the rubber part of the roof glass in the positions shown.
6. Attach the protection tapes to the roof in the positions shown.
7. Measure the rubber part of the roof glass from the center between the vehicle studs to the dimension shown, and cut off the rubber part.
8. Remove the protection tapes. Repeat the procedures on the other side.

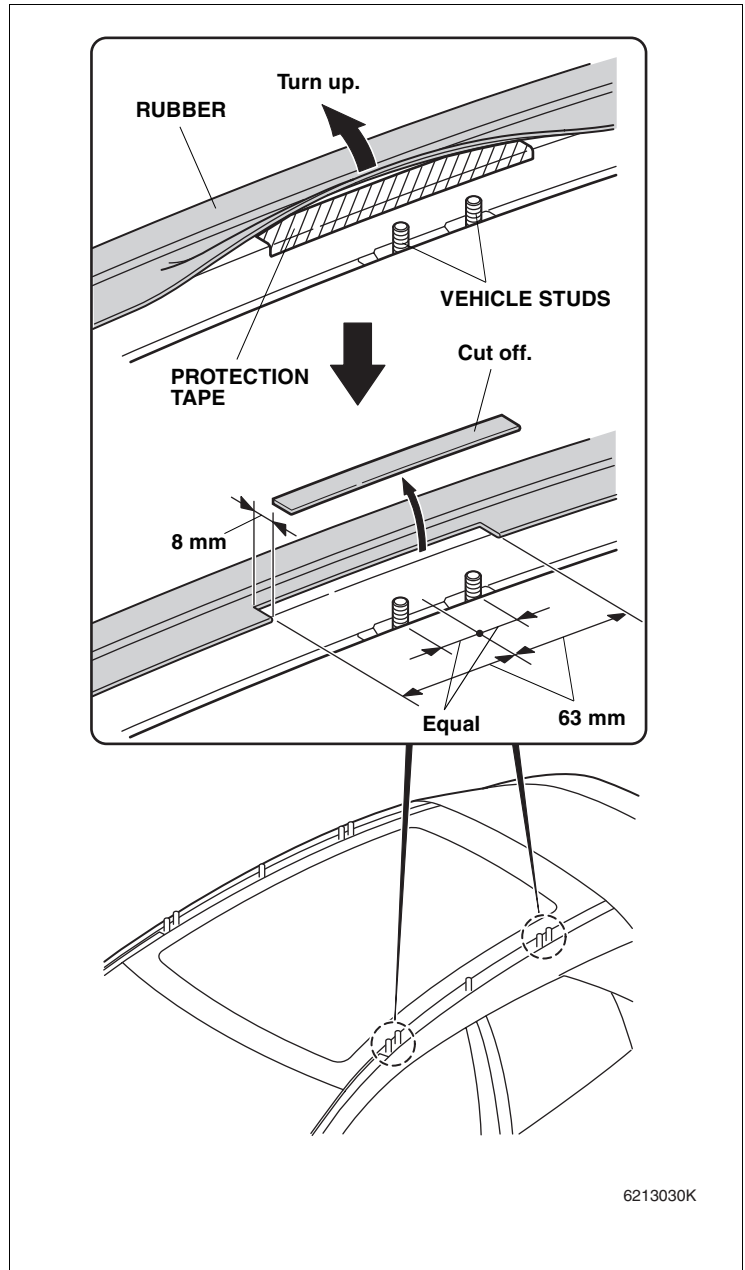

9. Install the right and left roof moldings with the ten retaining clips.

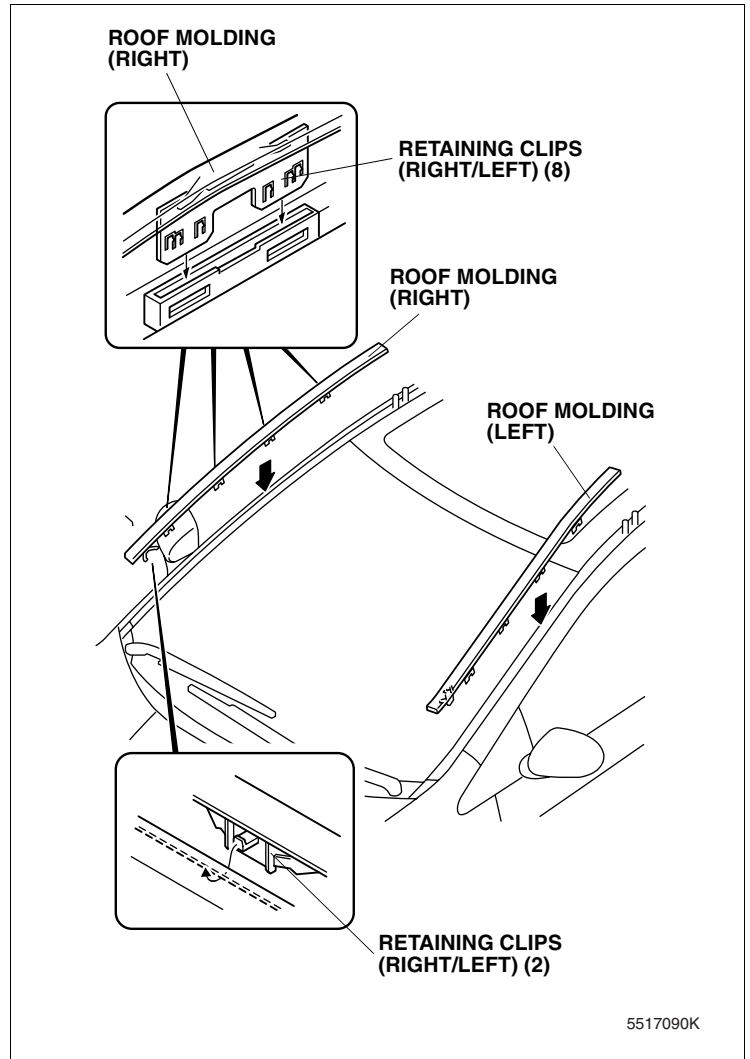

- Do not interchange the right and left drip side moldings.
- Take care not to damage the retaining clips.

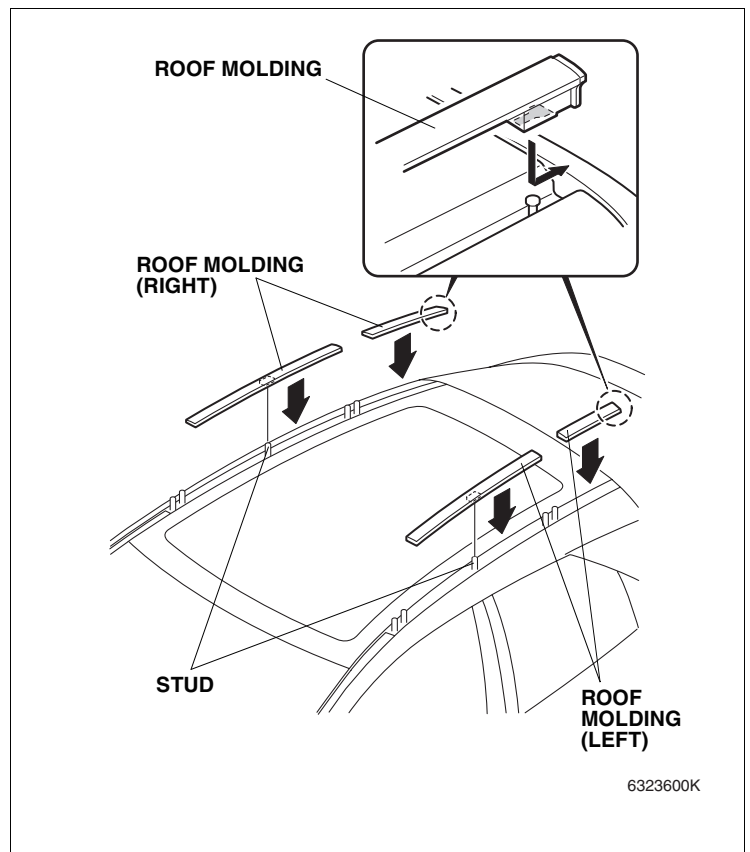

10. Using two special nuts, install the left base (front) and the front cushion (left) on the studs that remain in position after removing the roof molding.
 - Use the hex. wrench included in the kit to tighten the special nuts.
 - Tighten the special nuts securely by holding the hex. wrench as shown.

TORQUE: 10 N·m (1.0 kgf·m)
11. Install the left base (rear) and left cushion (left) in the same manner.
12. Repeat step 10 and 11 on the right side.

Model	Cushion	Right	Left
CIVIC (Glass roof)	Front	123042	123041
	Rear	123044	123043

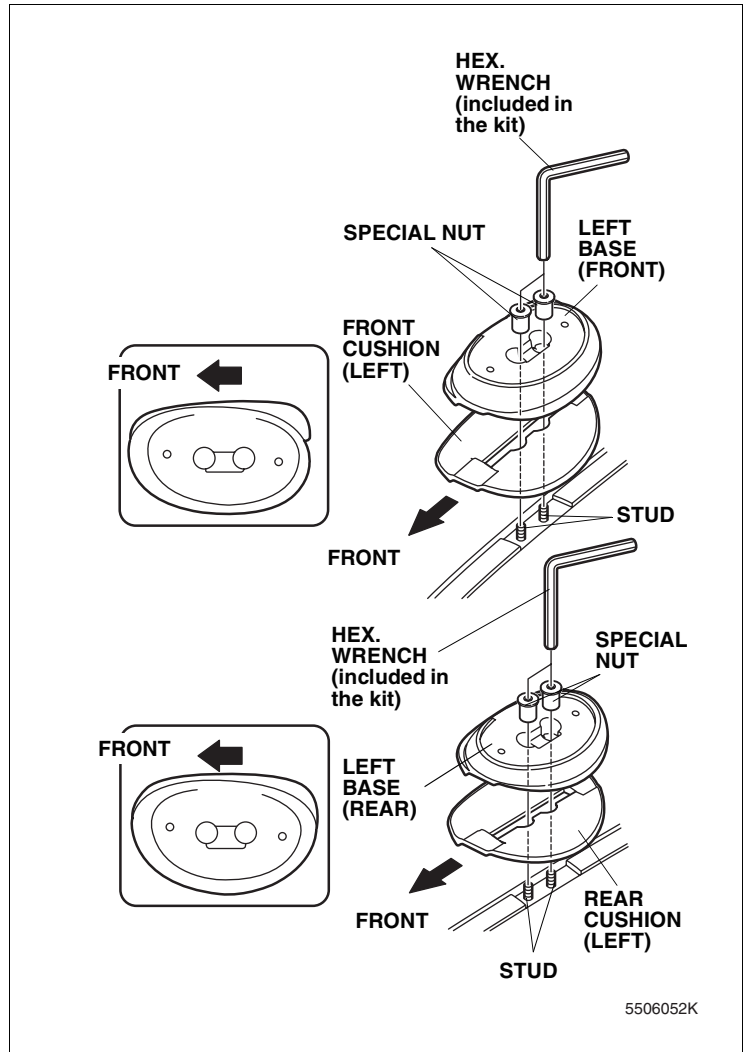

13. Open the cover of the roof carrier (front).
14. Insert the key plate into the roof carrier (front). Turn the key plate counterclockwise and remove the key cover from the carrier foot.
15. Repeat the procedure on the roof carrier (rear) and remove the key cover.
 - If you install the carrier clamps, see Installation Instructions "CARRIER CLAMP".

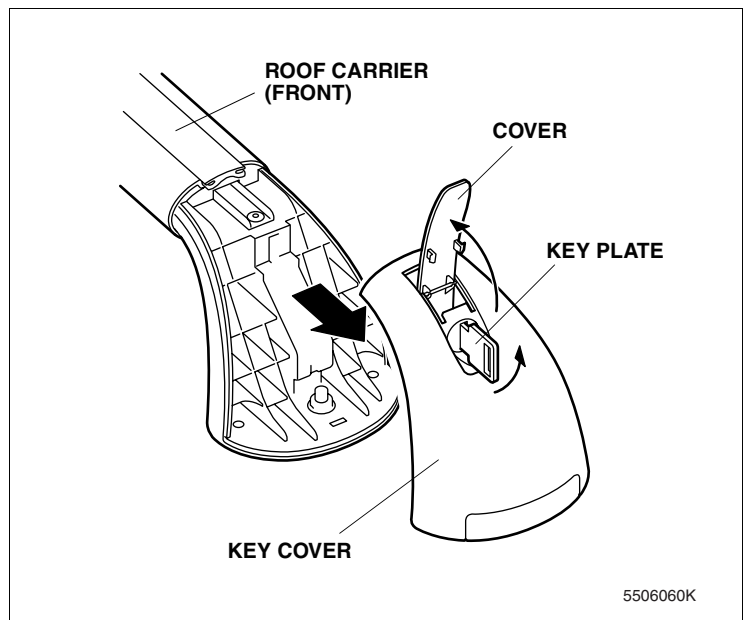

16. Install the roof carrier (front) on the front base (left) using two socket bolts and two plain washers.

TORQUE: 10 N·m (1.0 kgf·m)

17. Repeat the procedure on the other side.

18. Repeat the procedure on the roof carrier (rear).

- Note the caution seal direction on the inner side of the roof carrier.

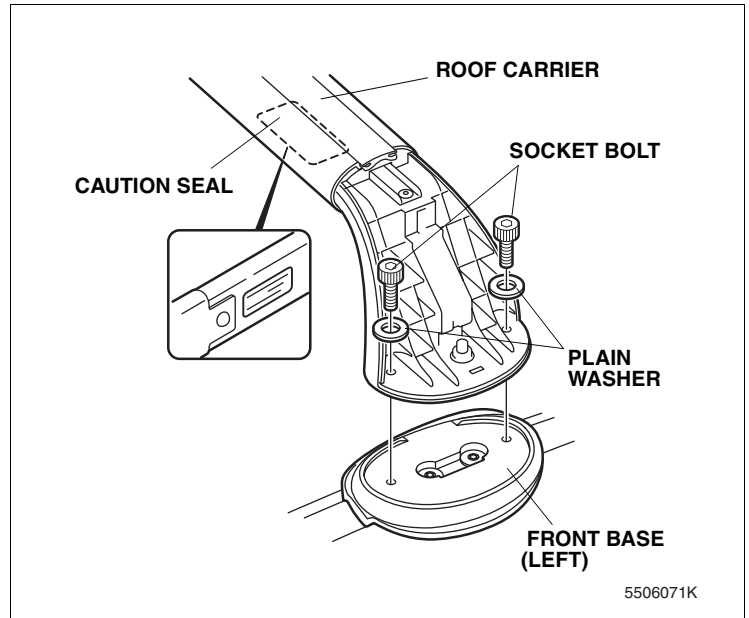

19. Install the key cover on the roof carrier. Insert the key plate into the roof carrier and turn it clockwise to secure the key cover.

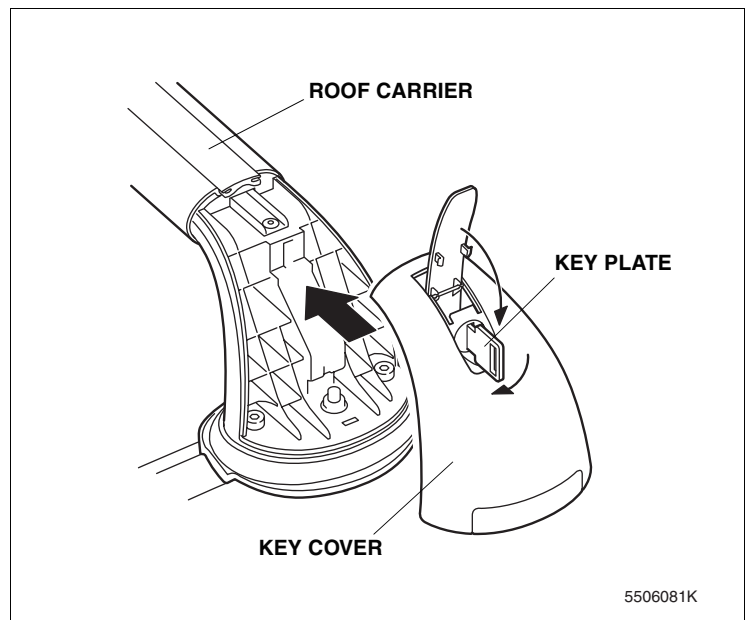

20. After installing the roof carrier, apply force on the front and rear sides and on the right and left sides of the roof carrier to check for secure installation.

- Be sure that the roof carrier is installed securely.
- Check the cushions for wobble. If there is wobbling in both or either of the cushions, retighten the special nuts of the cushion(s).

21. Record the number shown on the key plate.

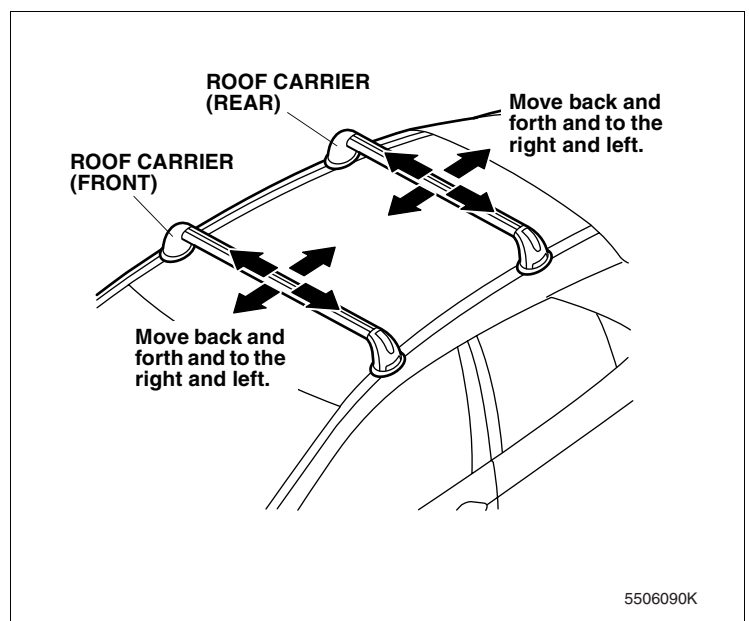

- Attach the four caps to the locations shown if the roof carriers and the carrier bases have been removed.

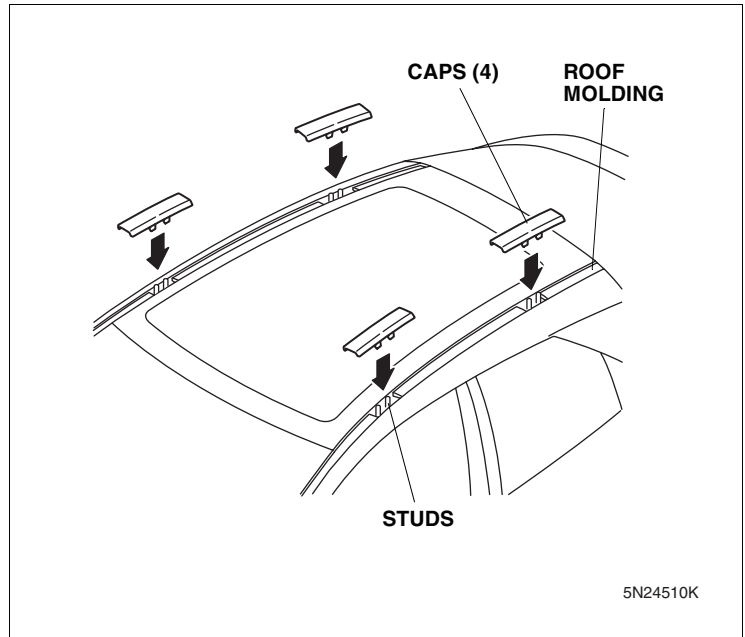

Use and Care

- The maximum allowable load (incl. weight of the base carriers, 5 kg) is 35 kg without carrier clamps on 55 kg with the carrier clamps.
- Do not overload. Make sure to fasten load so that it cannot come loose or cause damage. Be careful to secure load against movement in driving direction or sideways movements.
- When loading the roof carrier, please make sure that the weight is evenly distributed and that the center of gravity of the load is kept as low as possible. In case small, very heavy loads have to be transported ensure these are placed on one side of the load bar and not into the middle.
- For safety reasons, the load may not protrude from the vehicle outline.
- Before driving, make sure that all fastening parts are fixed according to regulations. Please check also if the load is fastened properly. Stop after a short drive to check screw connections and especially the foot attachments then check every time before driving.
- Please pay attention to the altered behavior to the vehicle (due to sidewind sensitivity, when driving in bends and when braking) when you drive a mounted (loaded) roof carrier. To safeguard other road users, and in order to reduce air resistance, the load carrier should be dismantled if it is not used.

Advice for your own security

IMPORTANT:

- This roof carrier is especially designed for your car model. Please therefore check with your retailer which type of base carrier is needed when changing your car.
- Test reports from the automotive industry and trade journals prove that when objects with large surfaces are transported, (e.g. surfboards, ski/transport boxes) the roof of the vehicle will be additionally strained due to the strongly increased air resistance. (When transporting a surfboard, the bow should point downwards in the driving direction.)
- The driving characteristics change as well; therefore we recommend you to adjust your speed accordingly.
- Do not put the car through an automatic car wash when the roof carrier is mounted.

The manufacturer takes no responsibility for damage caused by an incorrectly fitted roof carrier.

READ OWNER'S MANUAL CAREFULLY. The owner's manual has important safety and operation information.

These instructions should be considered a permanent part of the vehicle and should remain with the vehicle if sold.