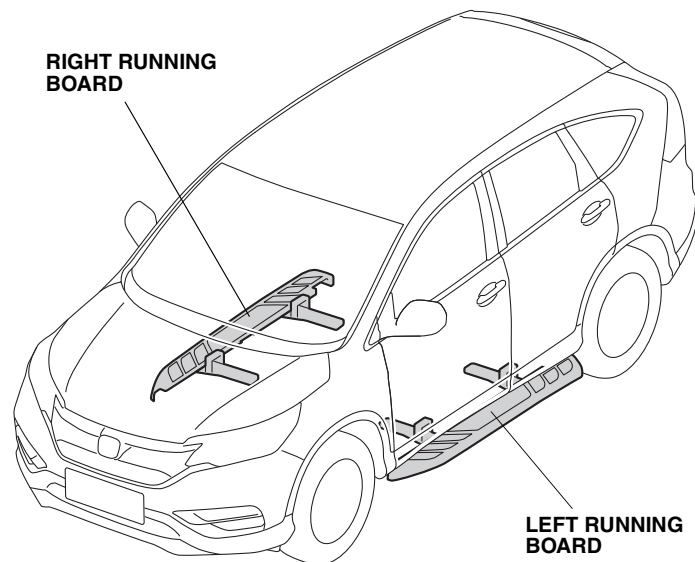

**RUNNING BOARDS****CR-V****GENERAL VIEW**

QD71606AA

**FOR YOUR SAFETY (Read carefully)****Introduction of Symbol Messages**

- These symbols warn you about the possible hazards and explain how to avoid them. And give you some advices.

**⚠ DANGER**

You will be killed or seriously hurt if you do not follow the instructions.

**⚠ WARNING**

You can be killed or seriously hurt if you do not follow the instructions.

**⚠ CAUTION**

You can be hurt if you do not follow the instructions.

**NOTICE**Gives advice to prevent damage to the product.  
Gives helpful information or instructions to be followed in using the product.

Indicates prohibited actions.

## Introduction of Icons

- These icons indicate the working place and the worker's vision.

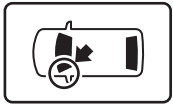

The place for the vehicle.

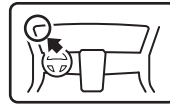

The place for the instrument panel.

- These icons indicate the necessary things for your safety and the work.



Wear eye protection.



Wear heavy gloves.



Work with an assistant.



Place the part on a blanket.



Remove any burrs.



Use the touch-up paint and dry.



Keep the parts and give it to the customer.  
(Not use)



Press firmly.



Tighten by specified torque.



Work perpendicularly.



Clean with the contact cleaner.

## Safety: General







- Observe all safety notes and precautions described in the Shop Manual in addition to those described in this Installation Instruction. Be extremely careful for your safety and safety of others particularly.
- Be careful not to damage the vehicle and the parts.
- Be extremely careful to the handling of the retaining tabs and clips particularly.
- Note the locations of the parts before removing them so that they can be reinstalled in their original positions properly.

## Safety: For the Accessory

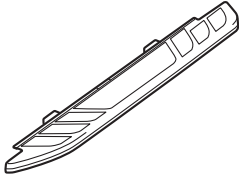
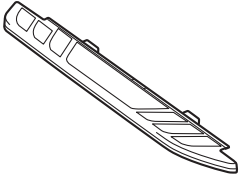
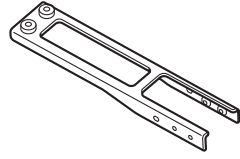
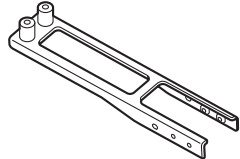
- Always use the parts and tools specified in the installation instructions.

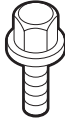
# PARTS LIST

## Running Boards Kit

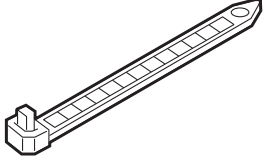
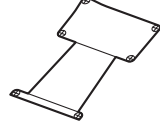
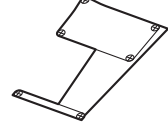
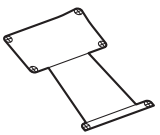
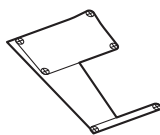
Left running board 	Right running board 	Brackets A (2) 	Brackets B (2) 
Brackets C (4) 	8 x 16 mm Bolts (32) 	8 x 25 mm Bolts (4) 	8 x 40 mm Bolts (4) 
Nuts (8) 	Wire ties (2) (Some may not used) 	Left front template (May not used) 	Left rear template (May not used) 
Right front template (May not used) 	Right rear template (May not used) 		

## TOOLS AND SUPPLIES REQUIRED

- Ratchet
- 3 mm, 6 mm, 8 mm, and 10 mm Drill bits
- Handy remover
- File
- Ruler
- 10 mm and 12 mm Sockets
- Eye protection (face shield, safety goggles, etc.)
- Utility knife
- Nippers
- Tape
- Drill
- Pushpin
- Torque wrench
- Hacksaw

# INSTALLATION

## Removing the Vehicle Parts

1. Lift up the vehicle.
2. Remove the left under cover.

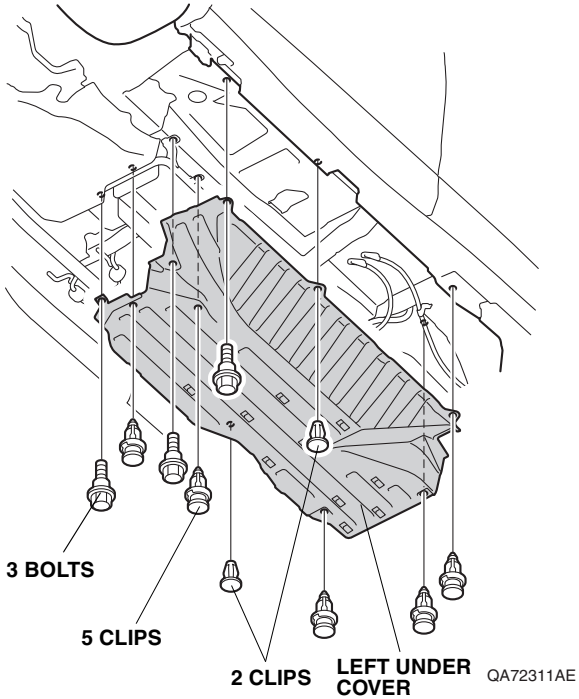
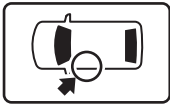

3. Remove the canister pipe guard.

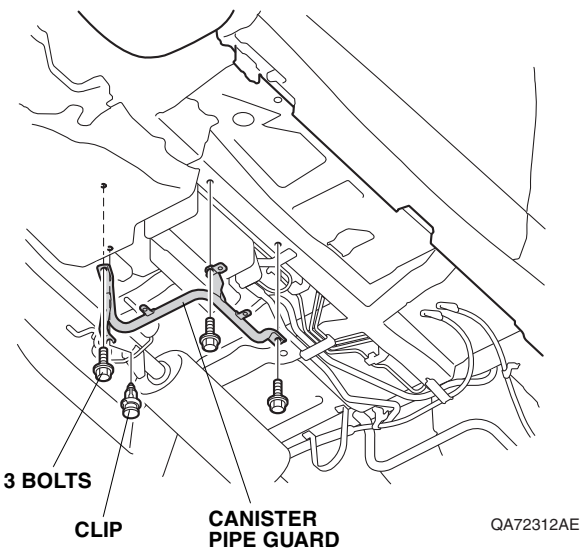

- |                                 |           |
|---------------------------------|-----------|
| • With fuel tank under guard    | To step 4 |
| • Without fuel tank under guard | To step 5 |

<With fuel tank under guard>

4. Remove the fuel tank under guard.

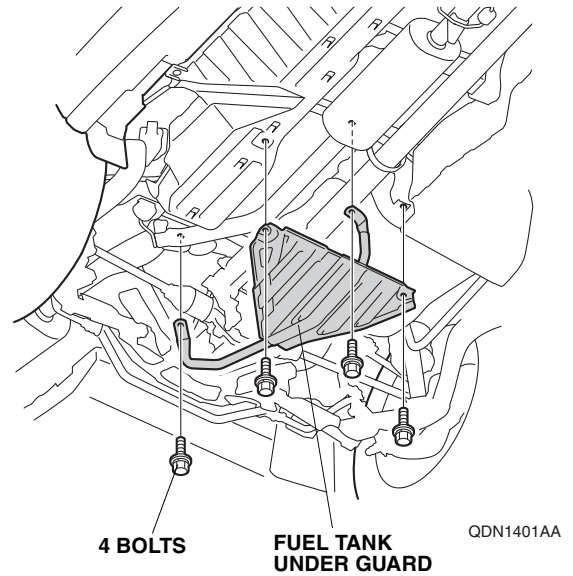
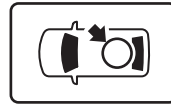

5. Remove the right under cover.

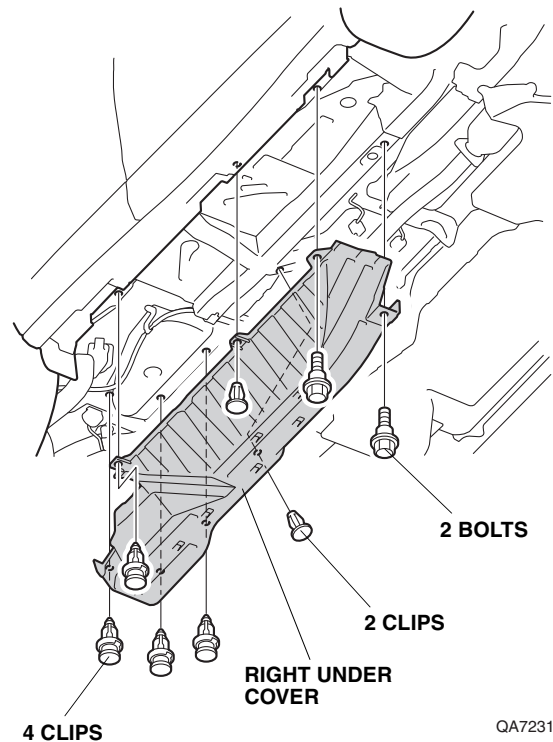
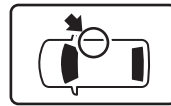

# Installing the Running Boards

- SWINDON factory in The U.K. models  
To step 6
- EAST LIBERTY factory in U.S.A. models  
To step 39
- AYUTTHAYA factory in THAILAND models  
To step 39

<SWINDON factory in The U.K. models>

6. Mark the left under cover.

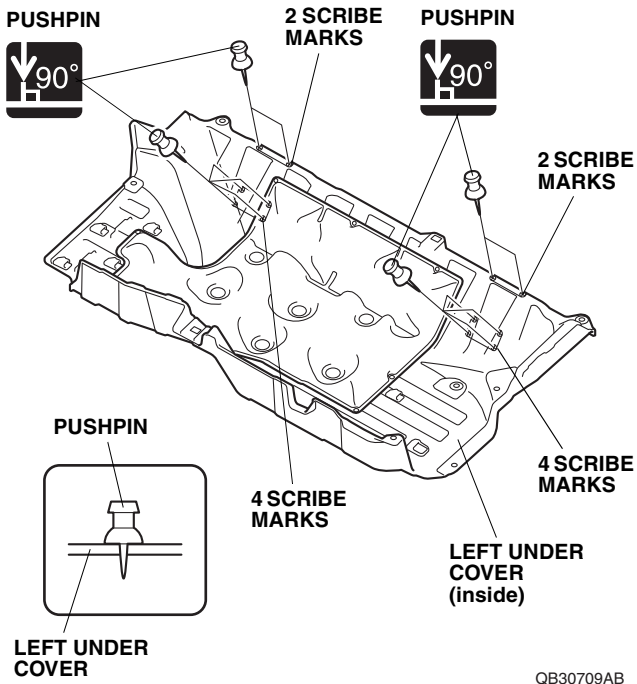

7. Drill the left under cover.

**NOTICE**

- Do not damage the insulator.

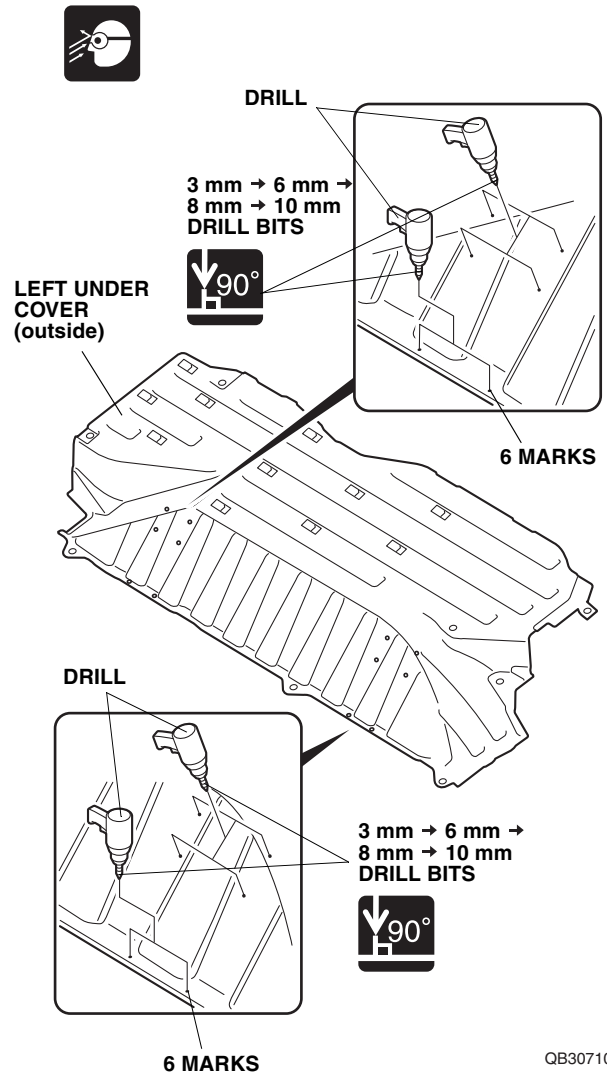

8. Cut the left under cover.

**NOTICE**

- Do not damage the insulator.

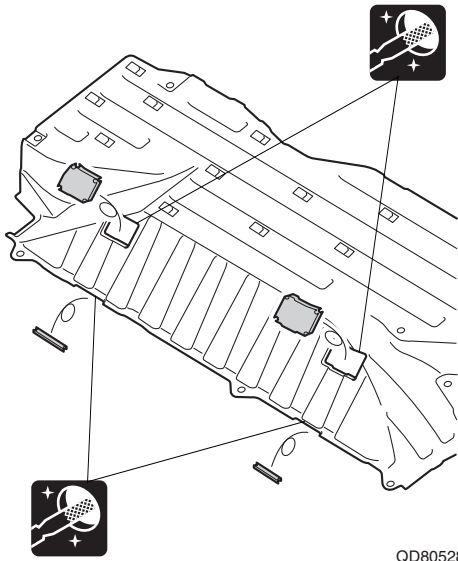

QD80528AA

- 2015 models To step 9
- ~2014 models To step 24

<2015 models>

9. Fold the insulator.  
10. Cut the insulator.

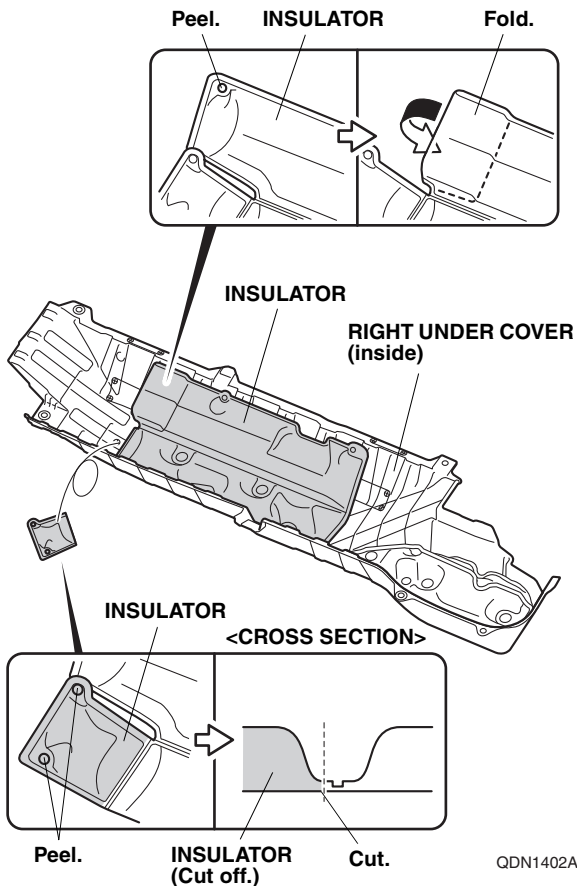

QDN1402AA

11. Check the scribe marks.

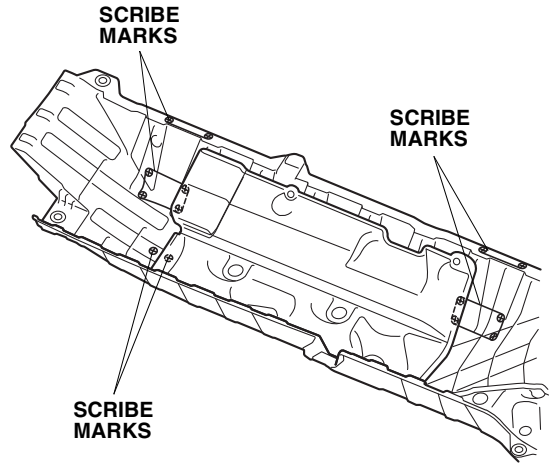

QDN1403AA

- With scribe marks To step 12
- Without scribe marks To step 15

<With scribe marks>

12. Mark the right under cover.

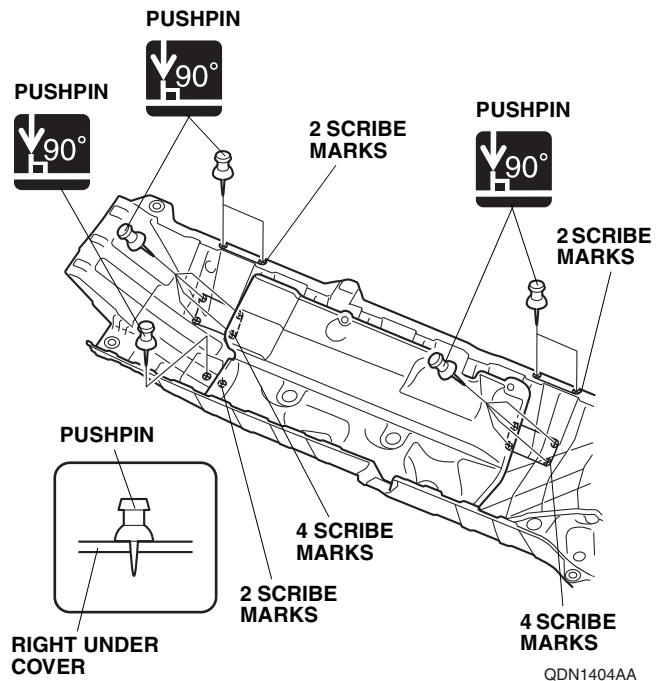

QDN1404AA

13. Drill the right under cover.

**NOTICE**

- Do not damage the insulator.

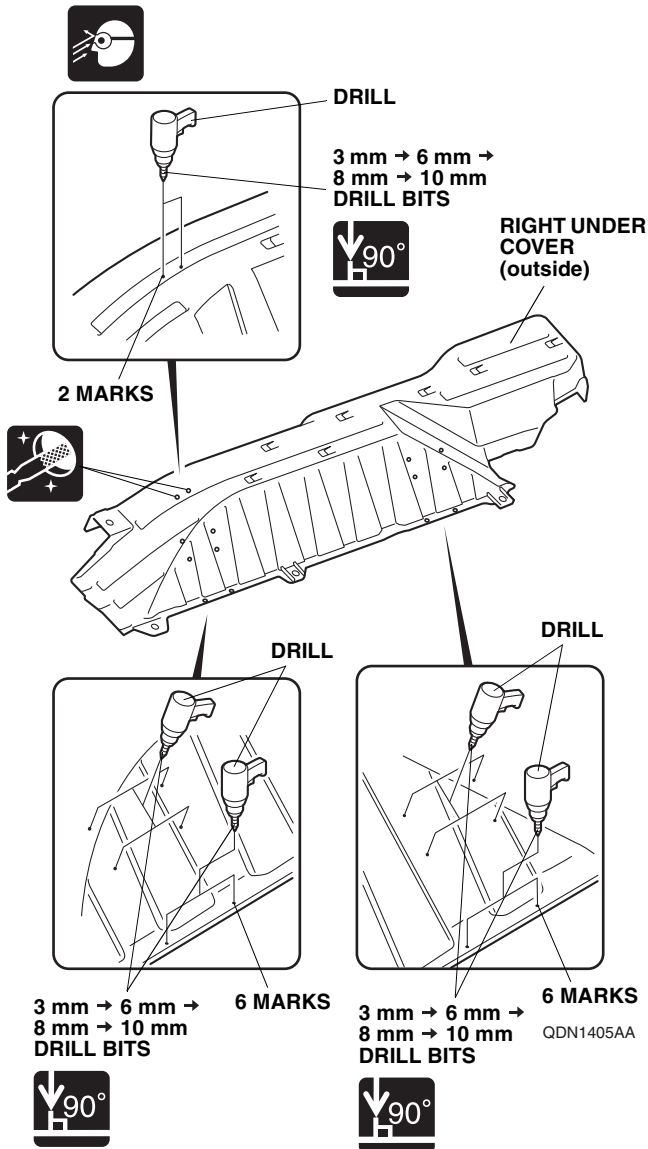

14. Cut the right under cover.

**NOTICE**

- Do not damage the insulator.

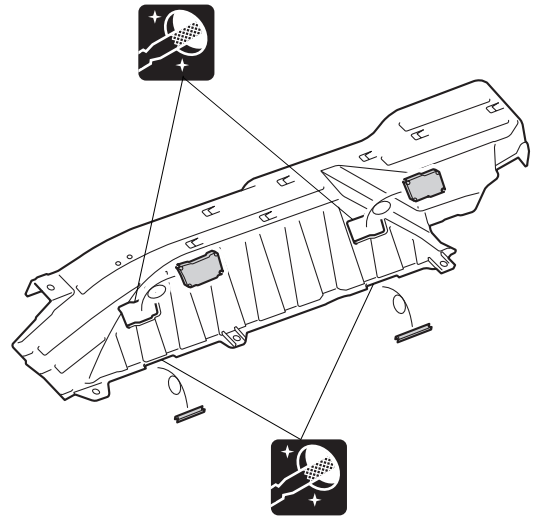

QDN1406AA

To step 22

<Without scribe marks>

15. Attach the right front template and right rear template.

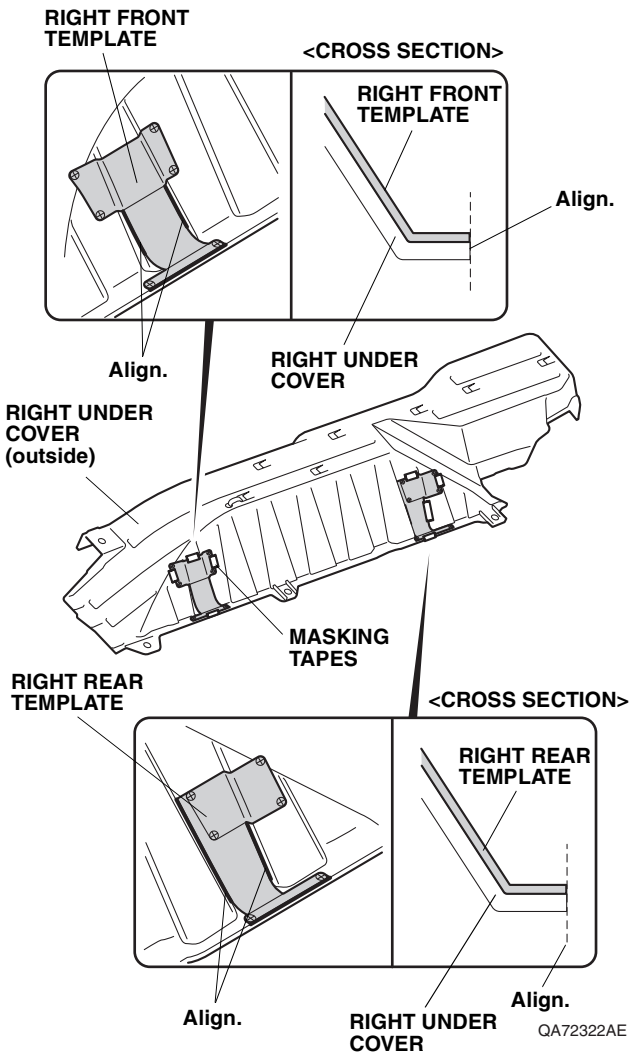

16. Mark the right under cover.
17. Remove the templates.

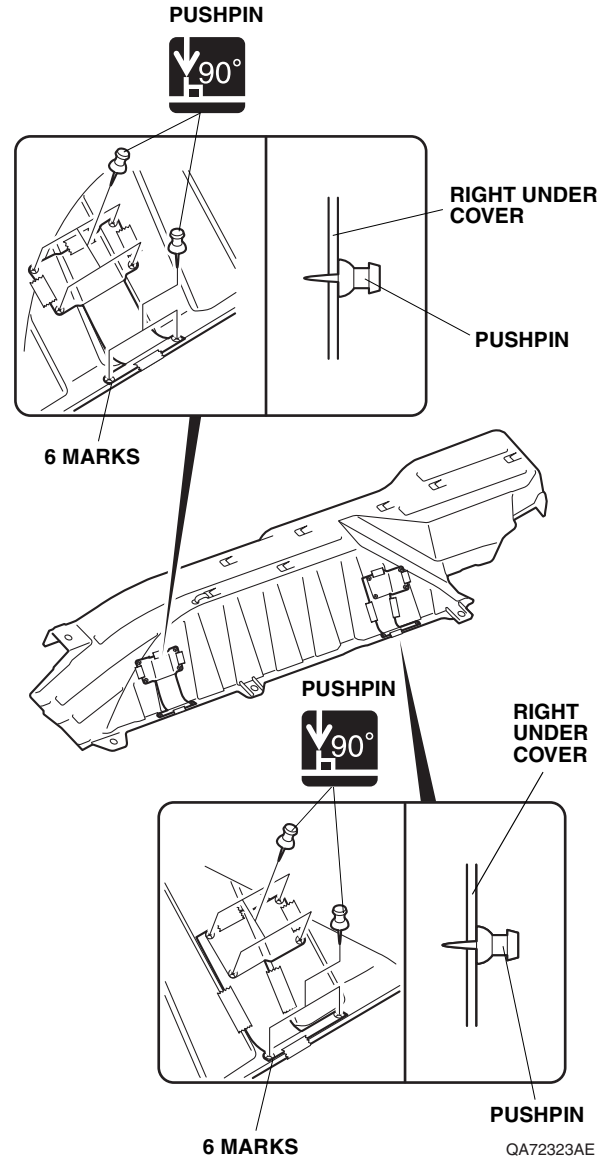



18. Drill the right under cover.

**NOTICE**

- Do not damage the insulator.

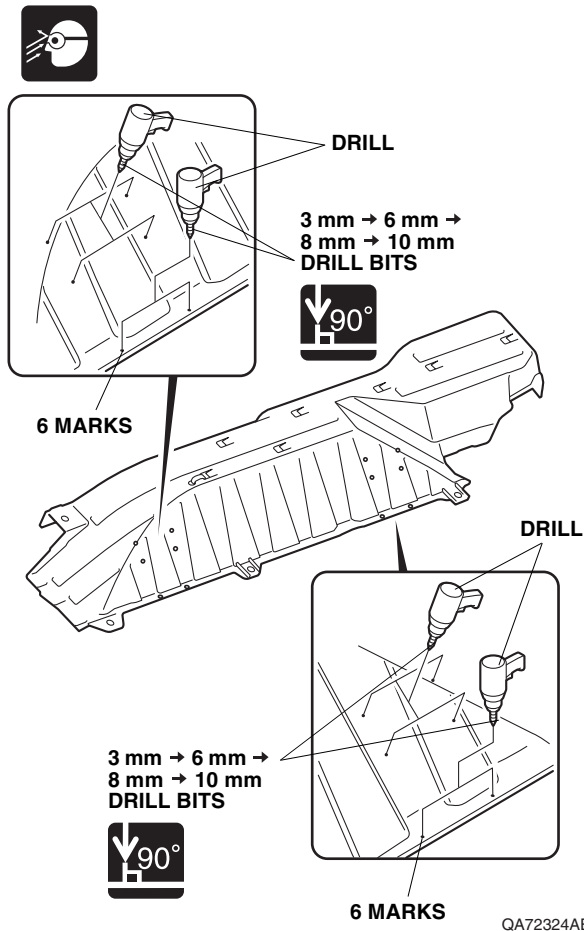

19. Cut the right under cover.

**NOTICE**

- Do not damage the insulator.

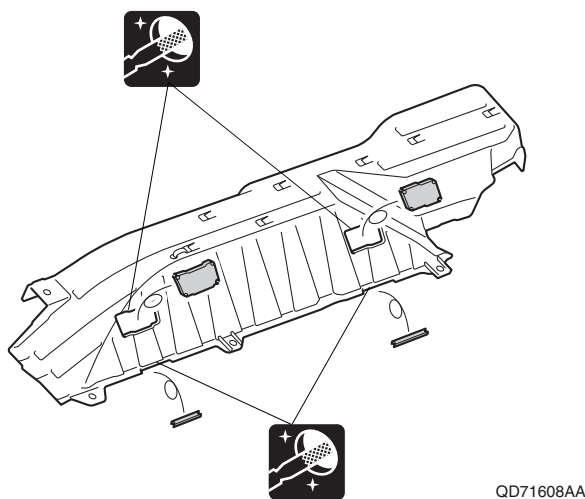

20. Mark the right under cover.

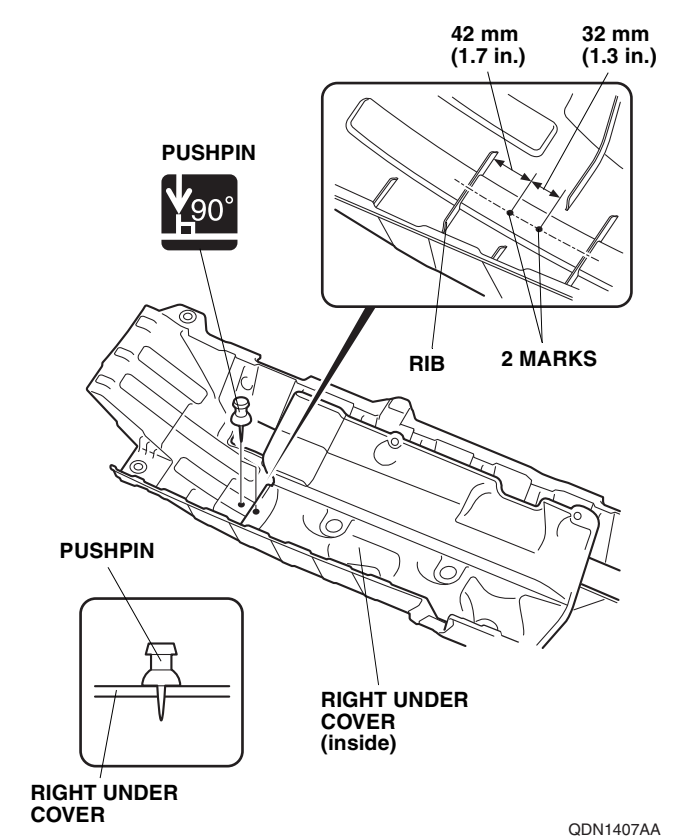

21. Drill the right under cover.

**NOTICE**

- Do not damage the insulator.

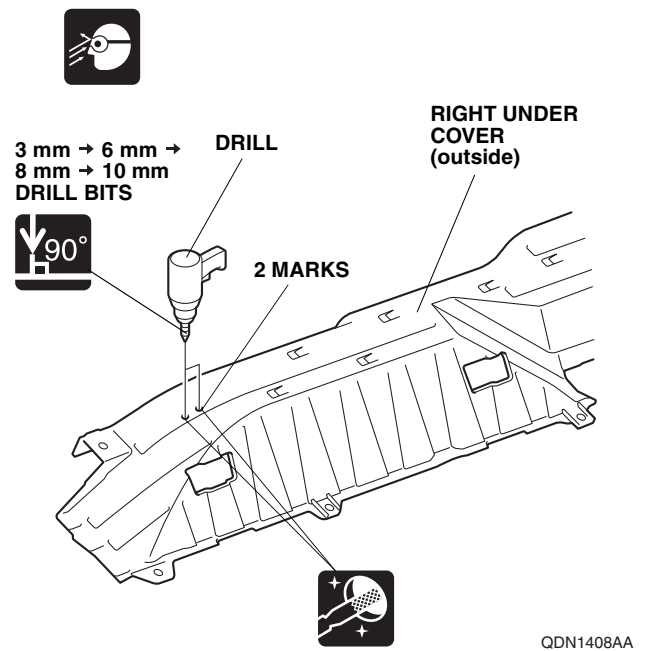

22. Cut the insulator.

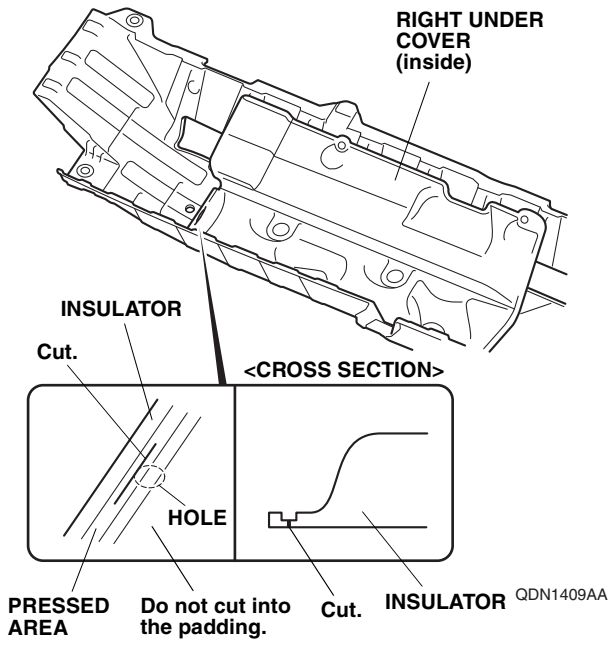

23. Secure the insulator.

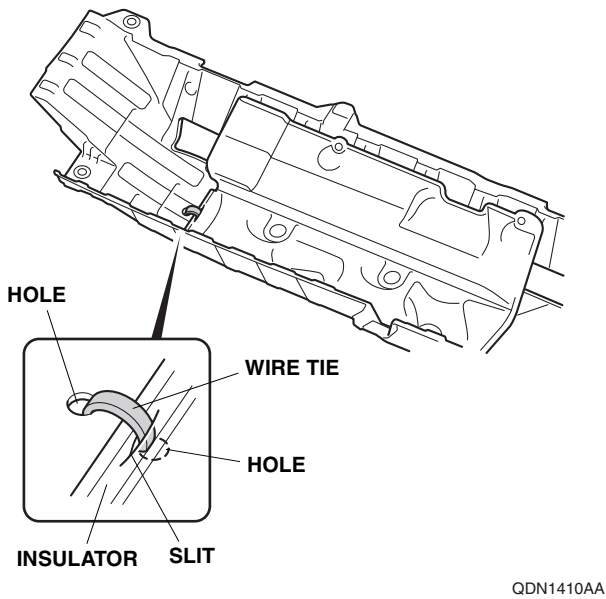

To step 53

<~2014 models>

24. Peel the insulator.

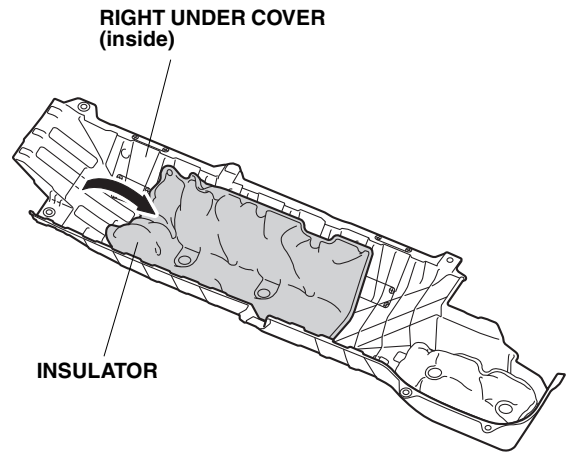

25. Check the scribe marks.

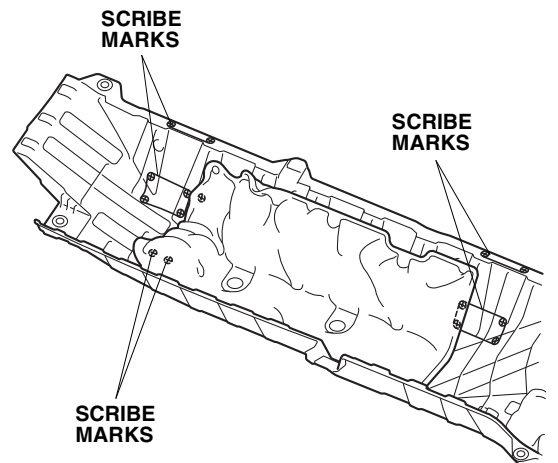

- With scribe marks

To step 26

- Without scribe marks

To step 29

<With scribe marks>

26. Mark the right under cover.

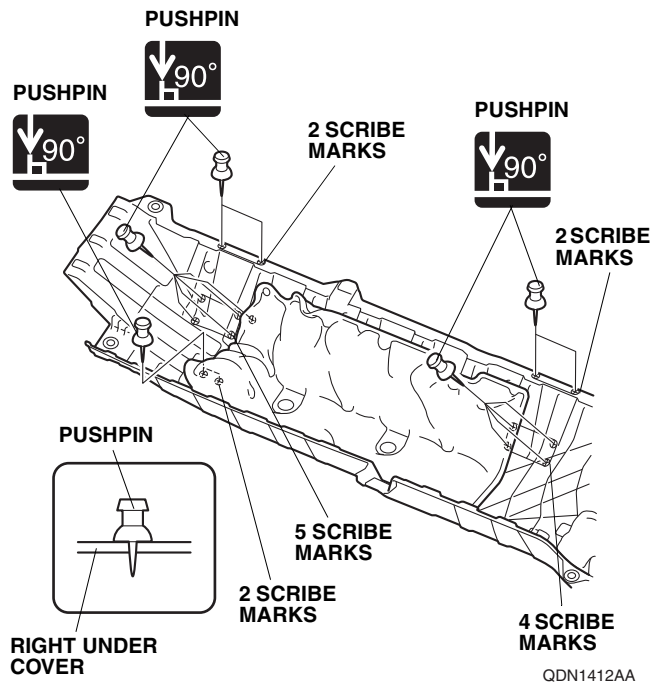

27. Drill the right under cover.

### NOTICE

- Do not damage the insulator.

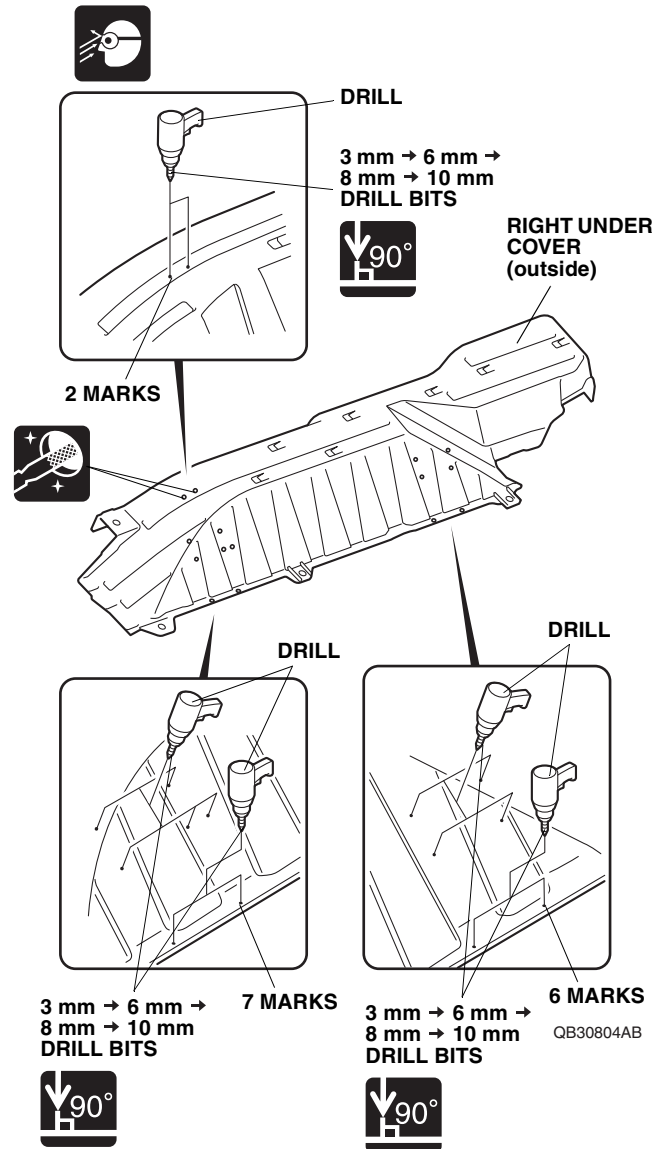

28. Cut the right under cover.

**NOTICE**

- Do not damage the insulator.

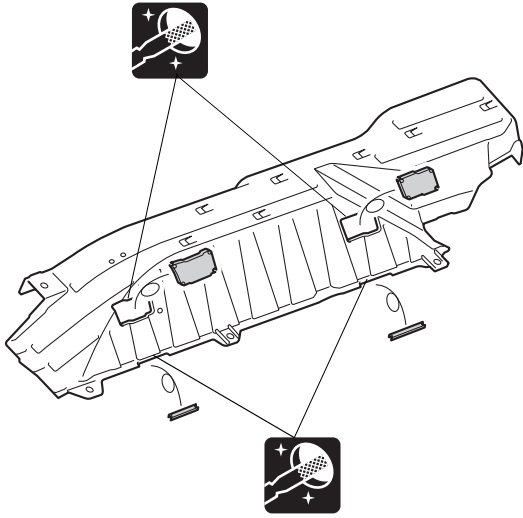

QD80529AA

To step 37

<Without scribe marks>

29. Attach the right front template and right rear template.

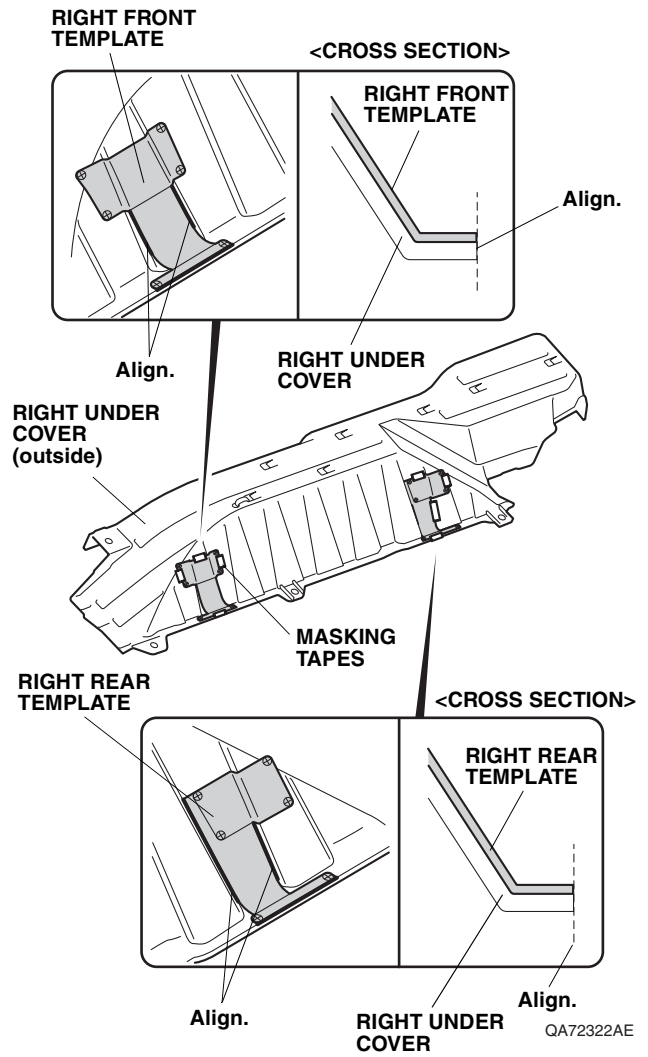

30. Mark the right under cover.
31. Remove the templates.

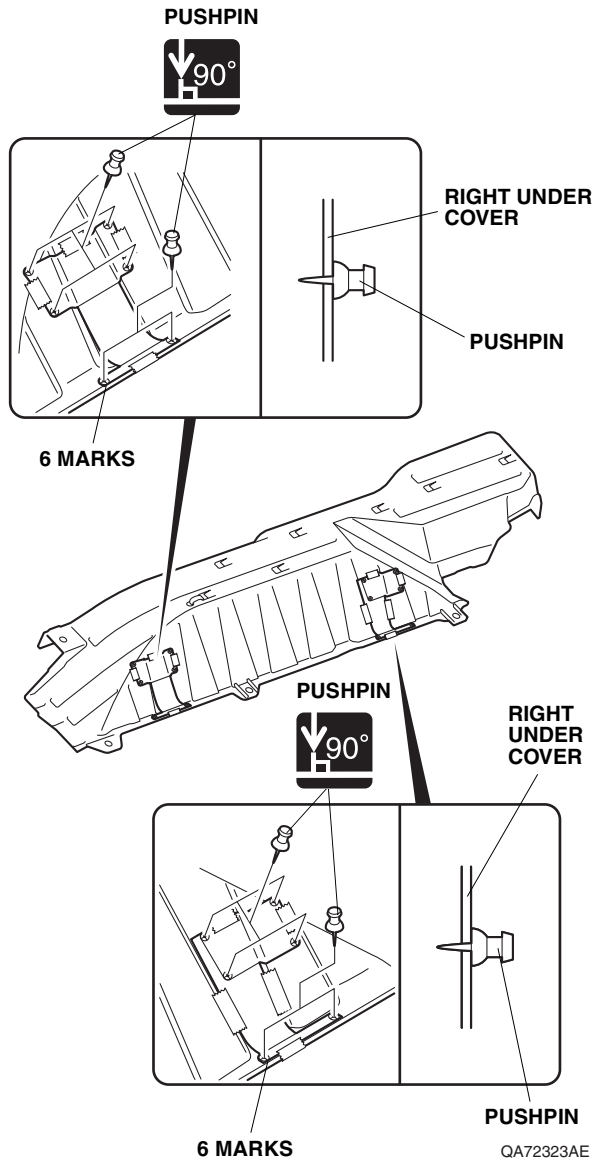

32. Drill the right under cover.

**NOTICE**

- Do not damage the insulator.

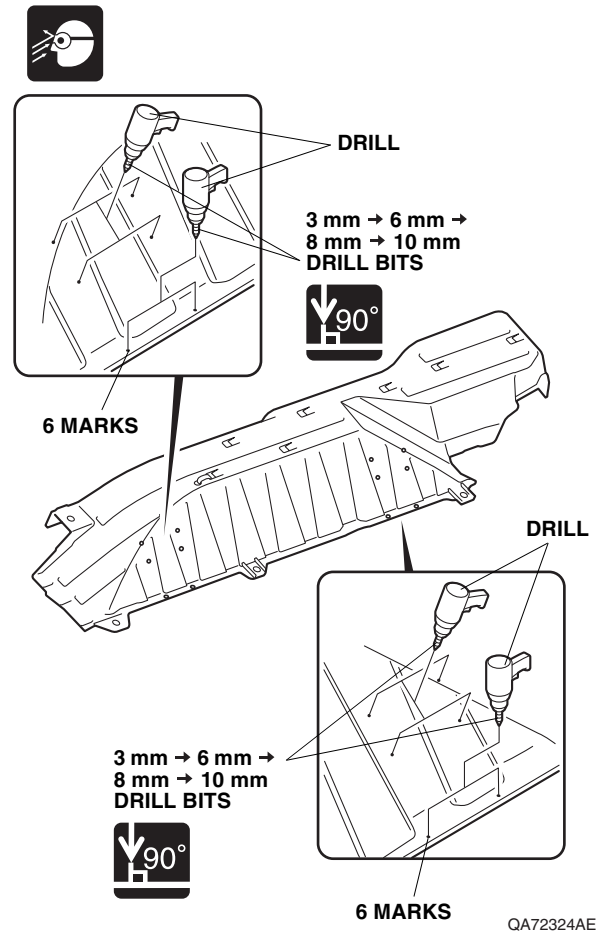

33. Cut the right under cover.

**NOTICE**

- Do not damage the insulator.

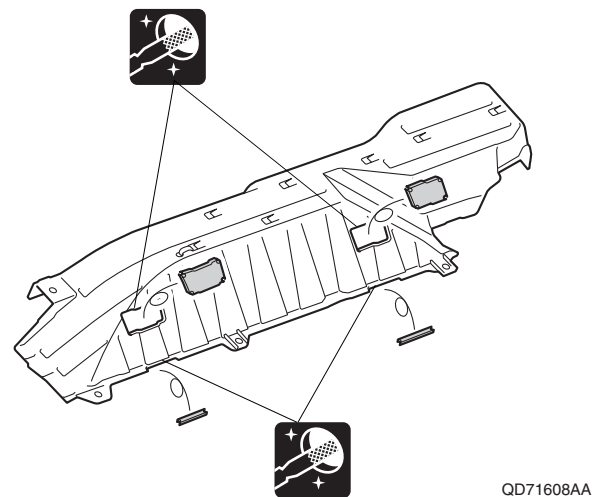

34. Mark the right under cover.

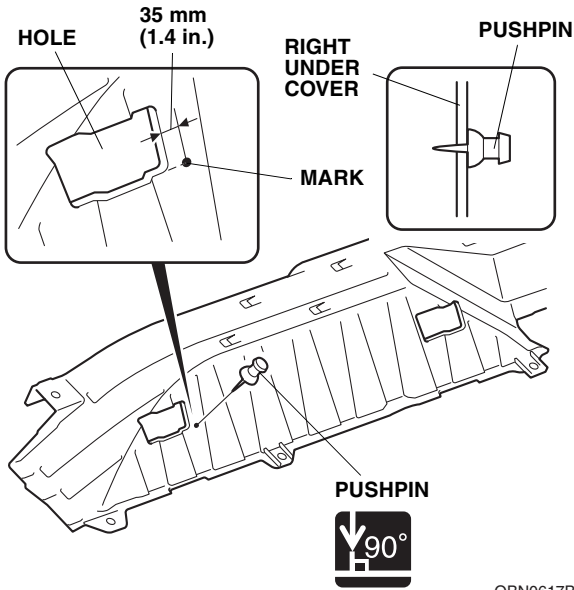

35. Mark the right under cover.

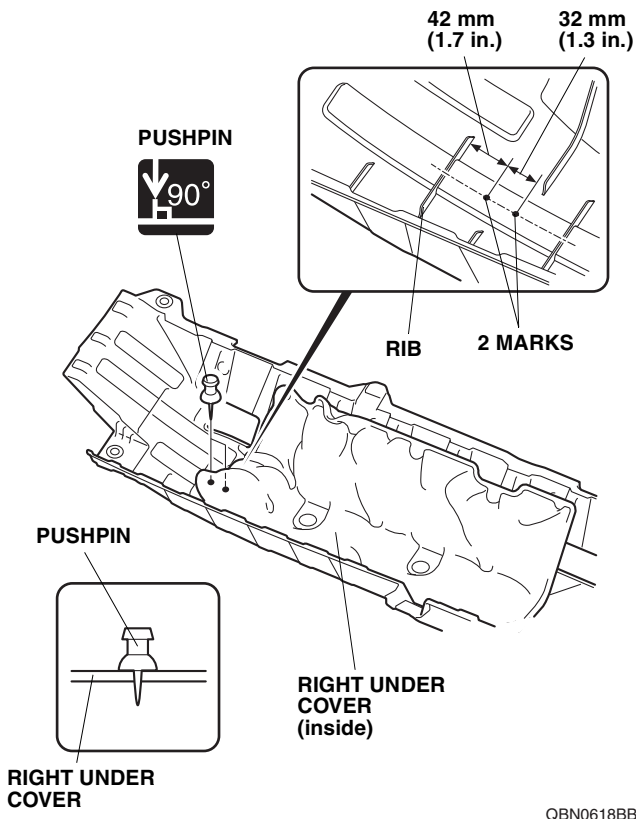

36. Drill the right under cover.

**NOTICE**

- Do not damage the insulator.

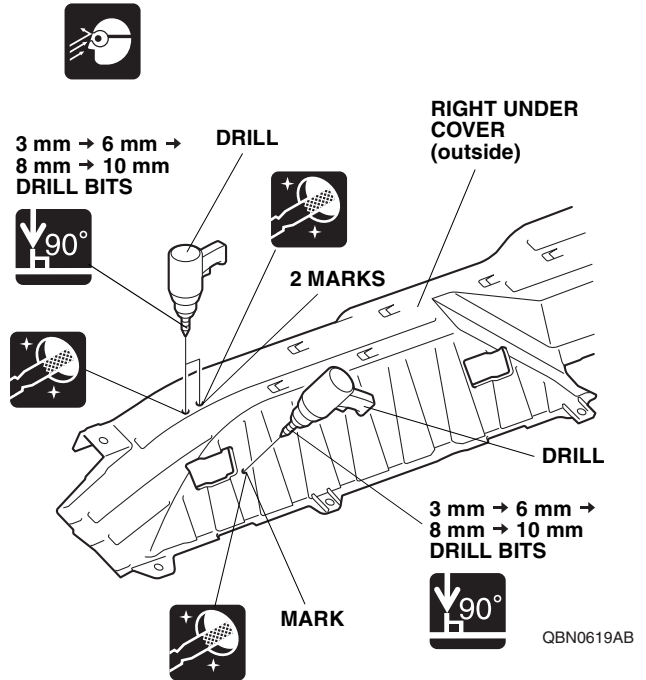

37. Cut the insulator.

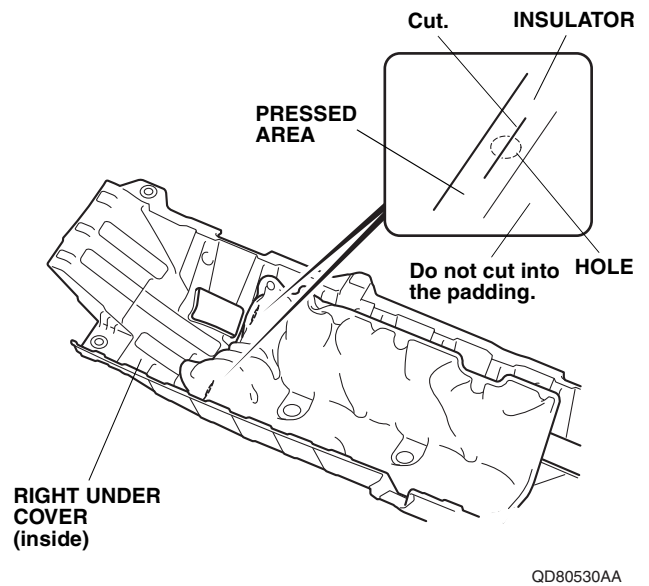

38. Secure the insulator.

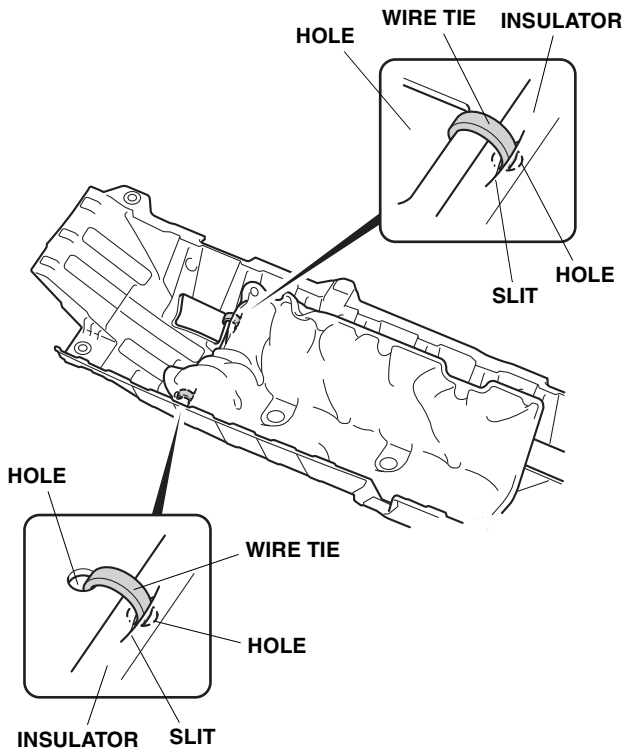

QB30807AB

To step 53

<EAST LIBERTY factory in U.S.A. models,  
AYUTTHAYA factory in THAILAND models>

39. Attach the left front template and left rear template.

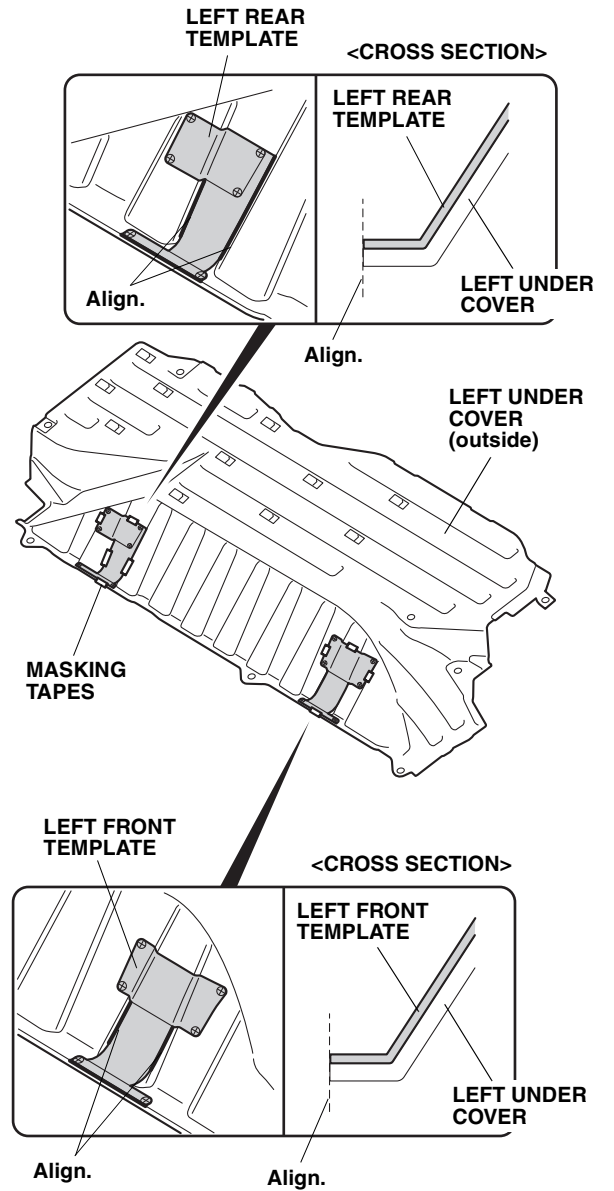

QA72314AE

- 40. Mark the left under cover.
- 41. Remove the templates.

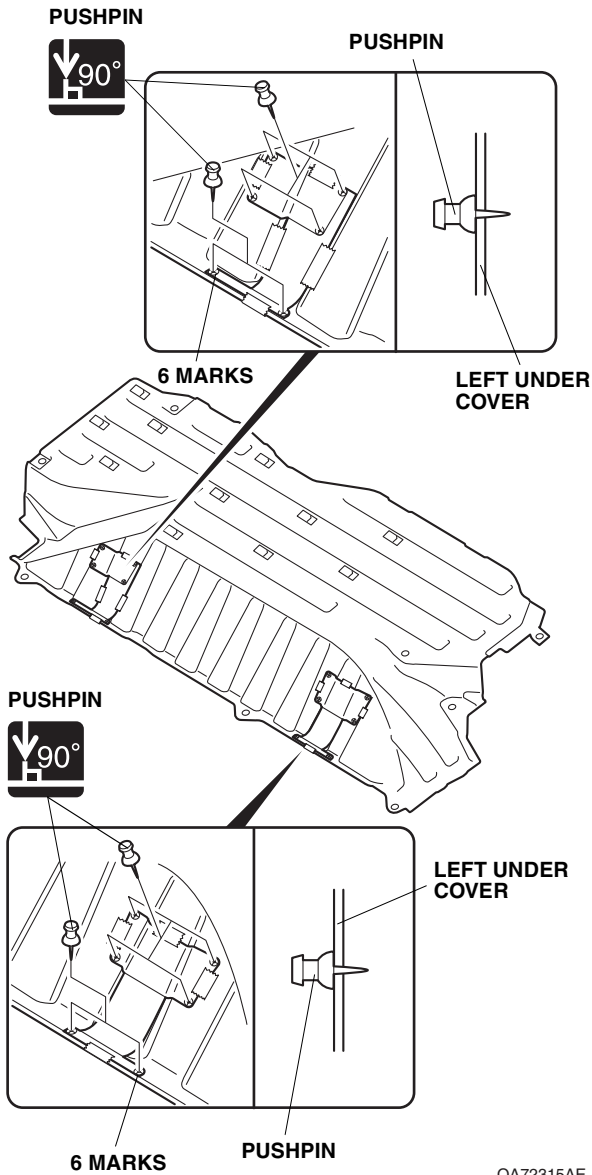

QA72315AE

- 42. Drill the left under cover.

**NOTICE**

- Do not damage the insulator.

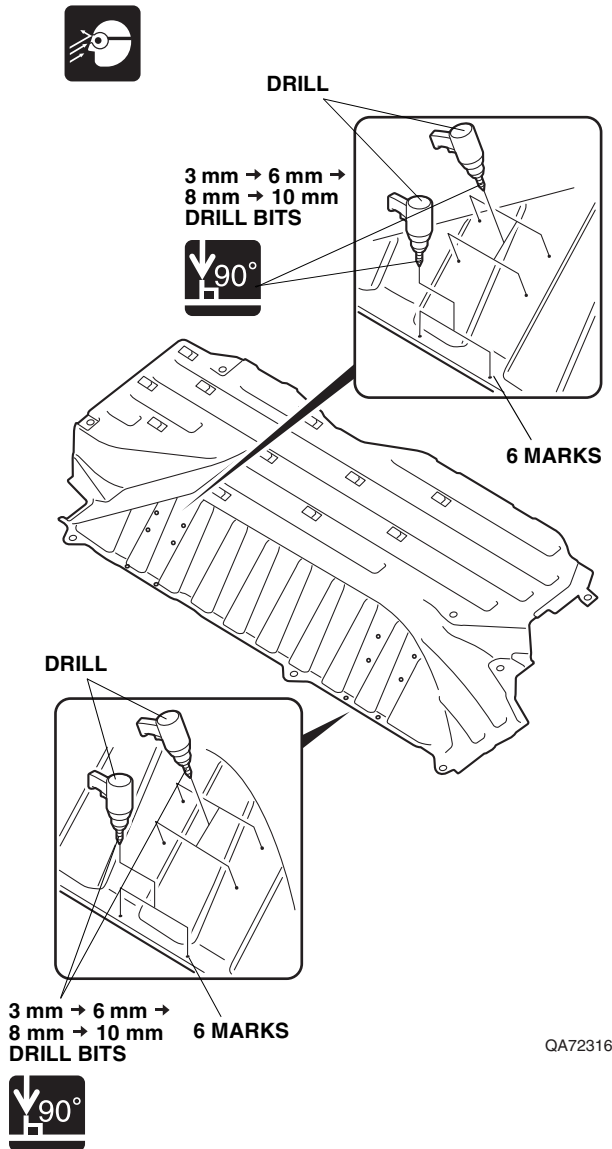

QA72316AE



43. Cut the left under cover.

**NOTICE**

- Do not damage the insulator.

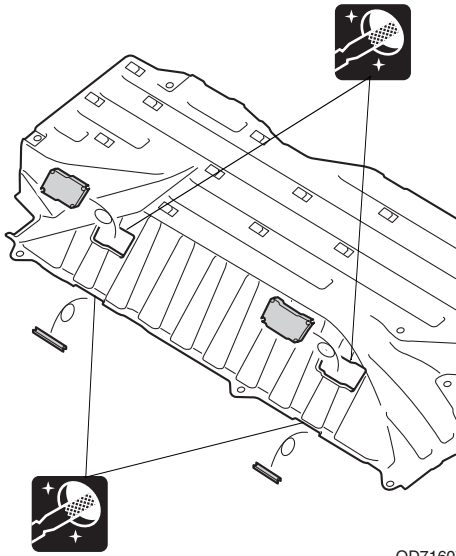

QD71607AA

44. Peel the insulator.

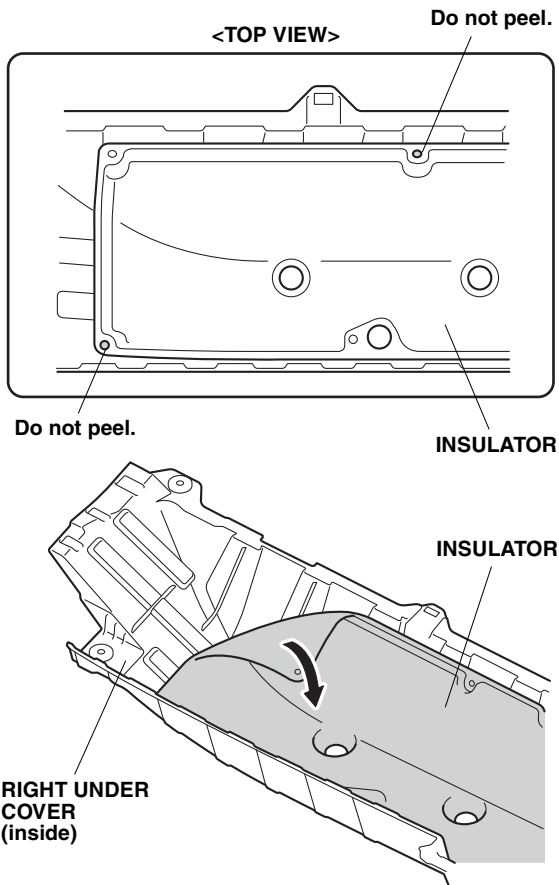

QA72320BE

45. Mark the right under cover.

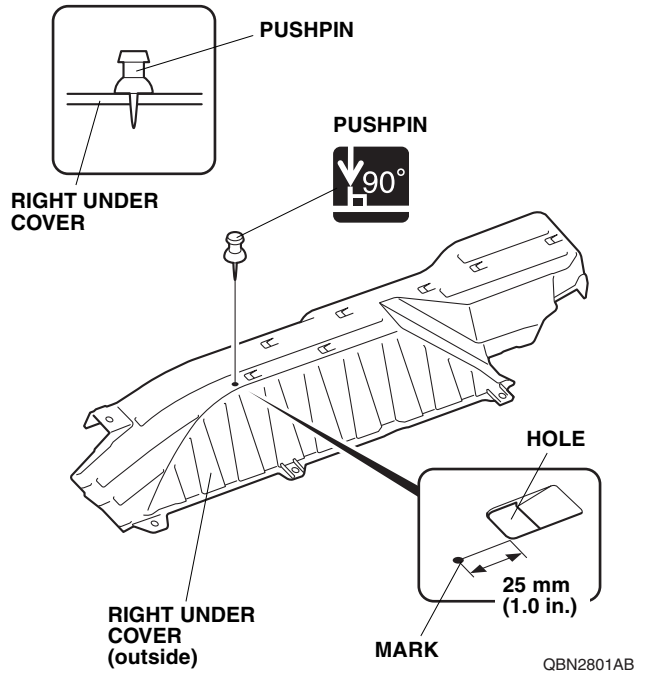

46. Drill the right under cover.

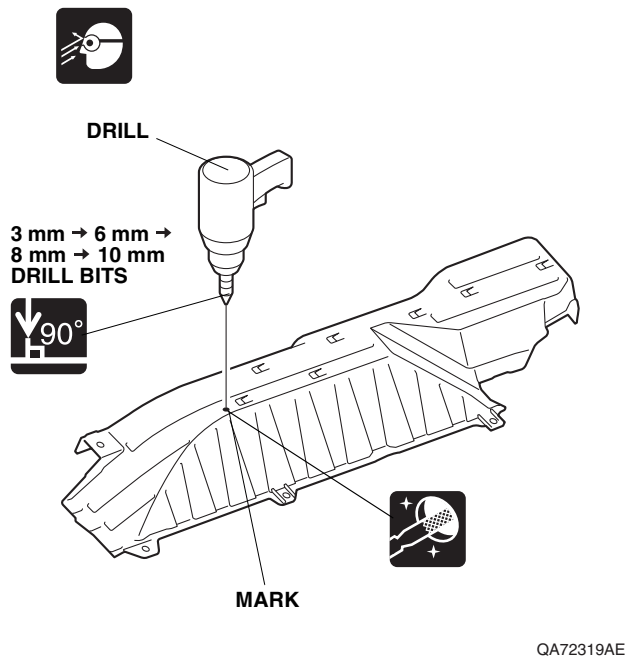

47. Secure the insulator.

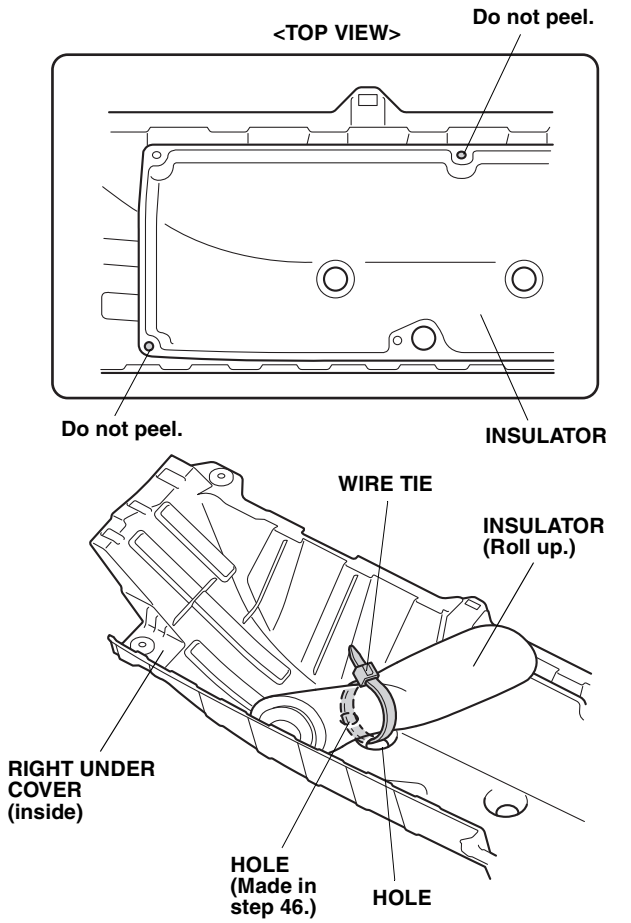

48. Attach the right front template and right rear template.

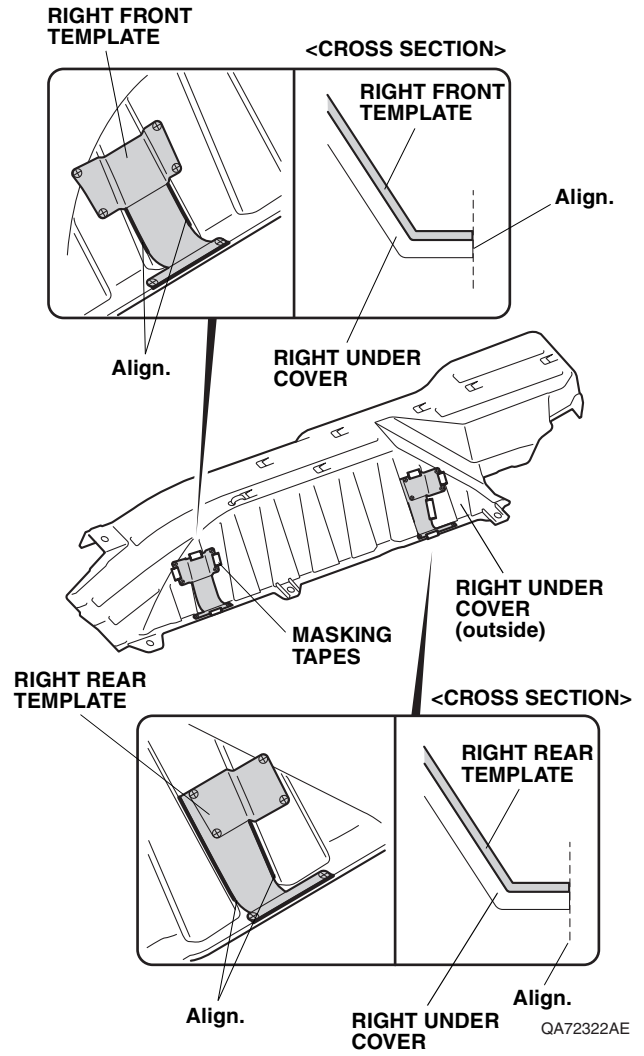

49. Mark the right under cover.
50. Remove the templates.

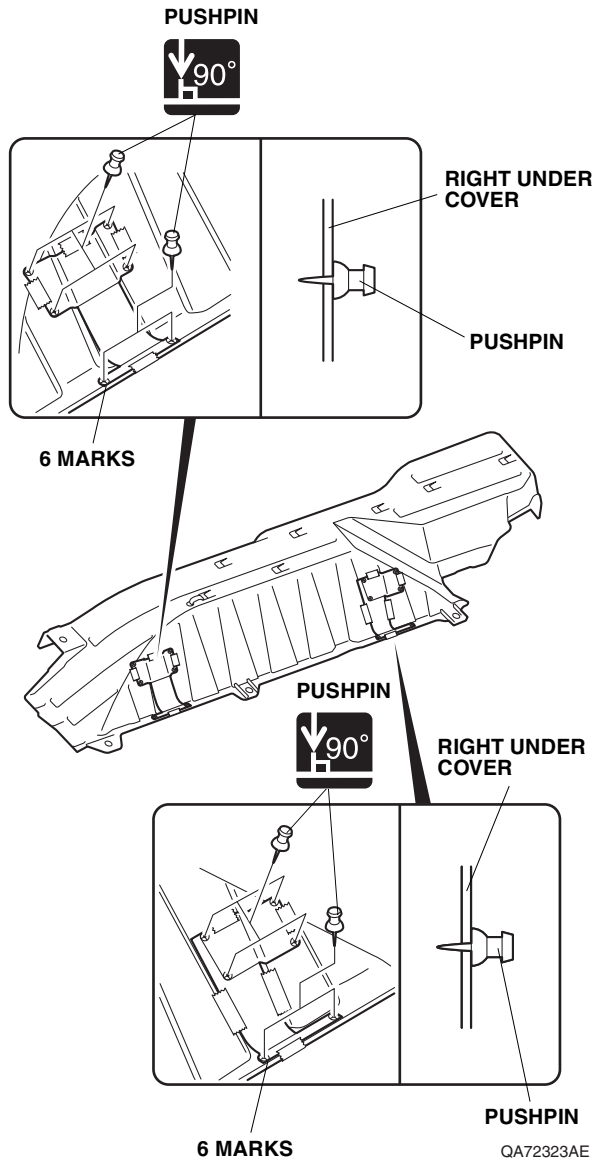

51. Drill the right under cover.

**NOTICE**

- Do not damage the insulator.

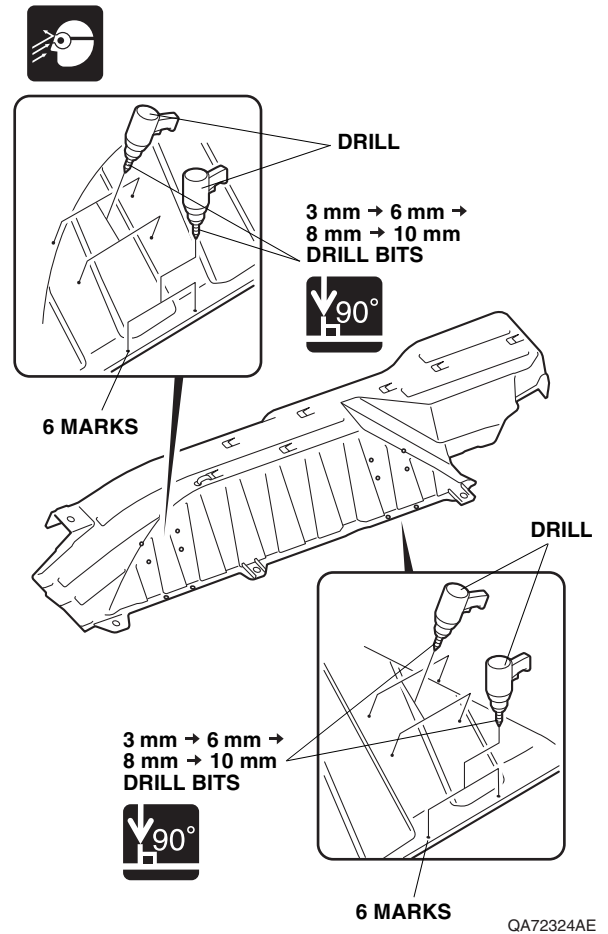

52. Cut the right under cover.

**NOTICE**

- Do not damage the insulator.

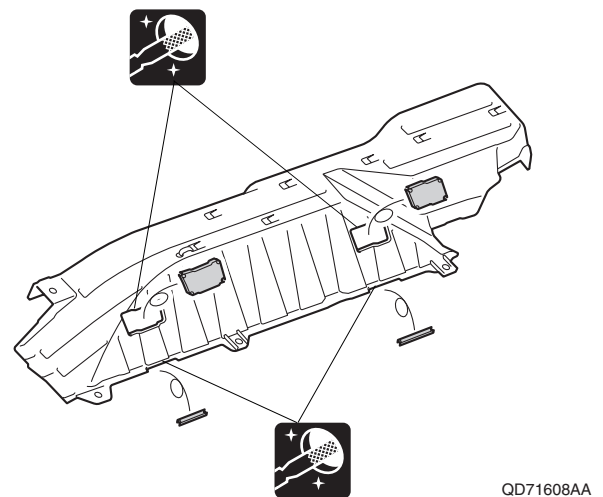

53. Loosely secure the bracket C.

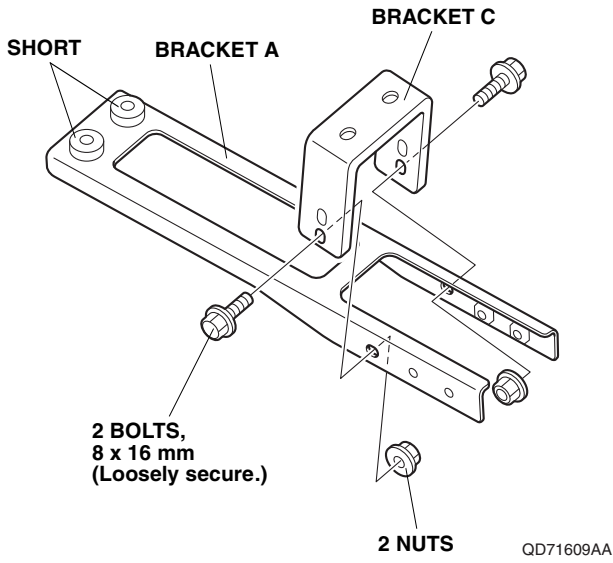

54. Loosely secure the bracket C.

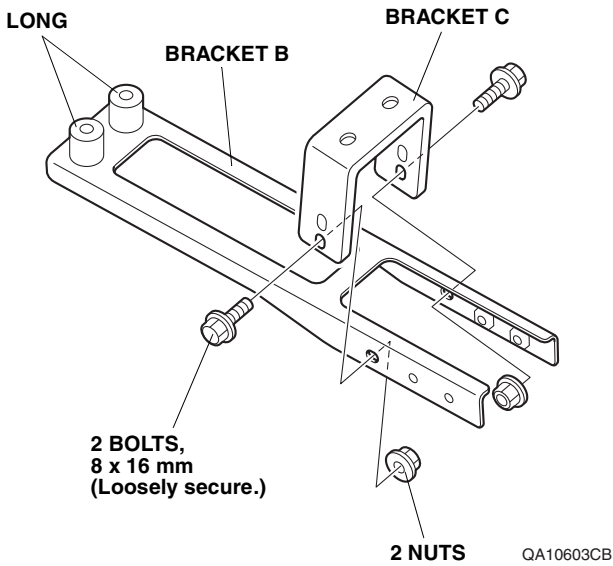

55. Insert the bracket A and bracket B.

56. Loosely secure the bracket A and bracket B.

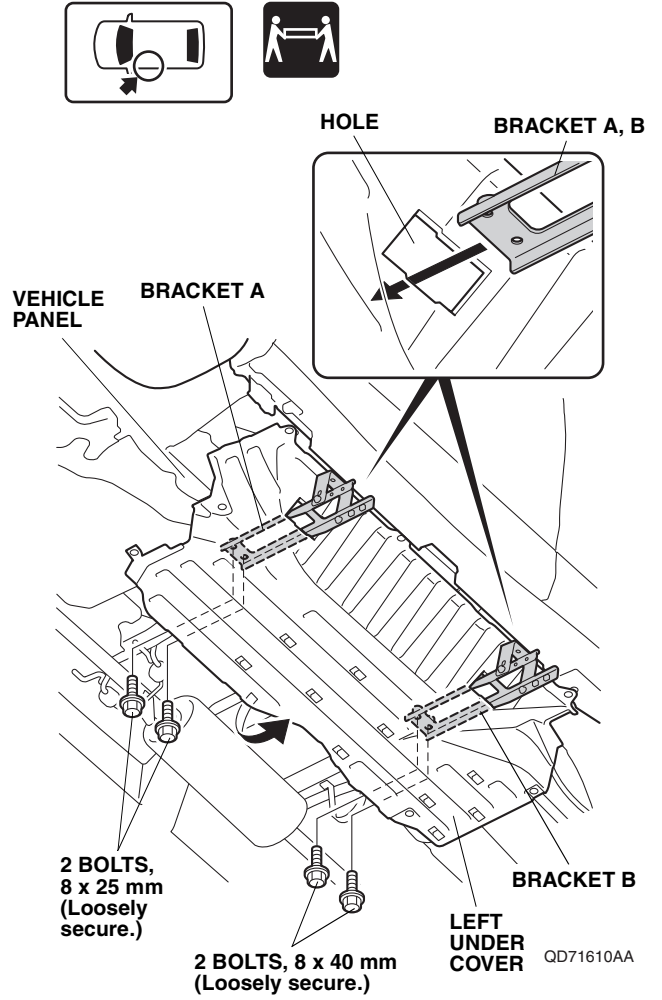

57. Loosely secure the brackets C.

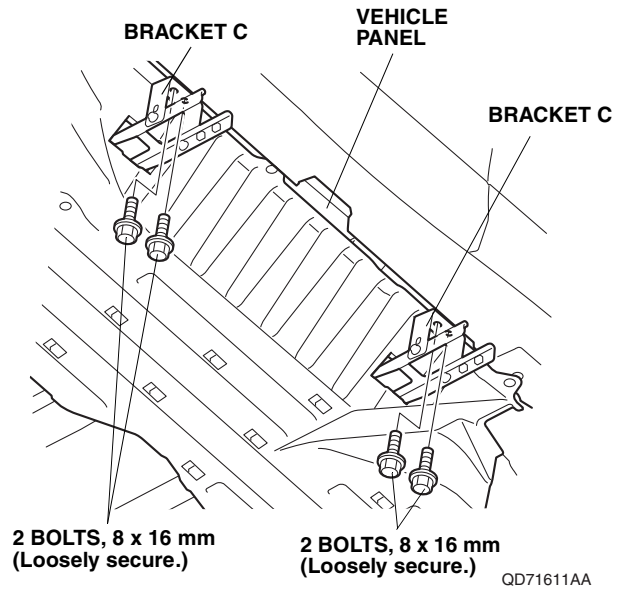

58. Loosely secure the left running board.

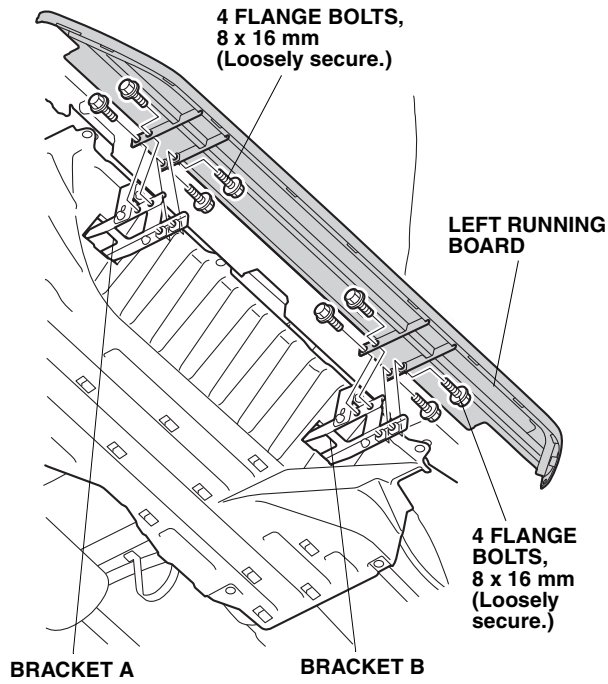

QD71612AA

59. Secure the bracket A and bracket B.

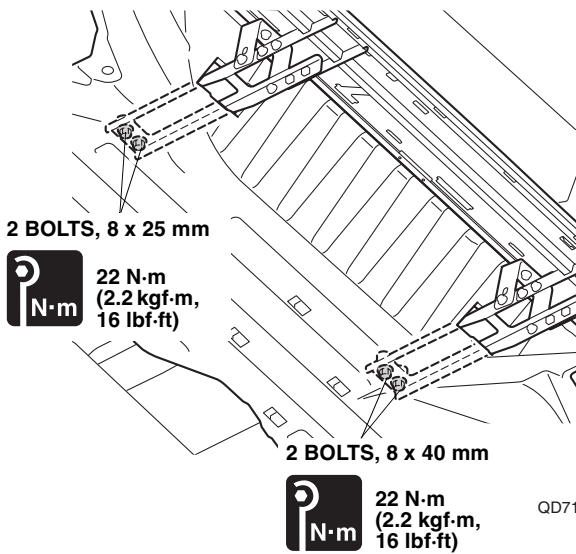

QD71613AA

60. Secure the brackets C.

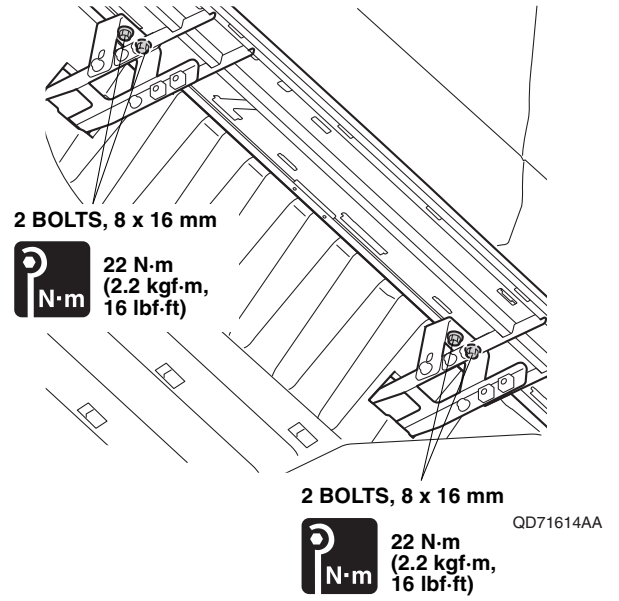

QD71614AA

61. Secure the bracket C (FR) and bracket D (RR).

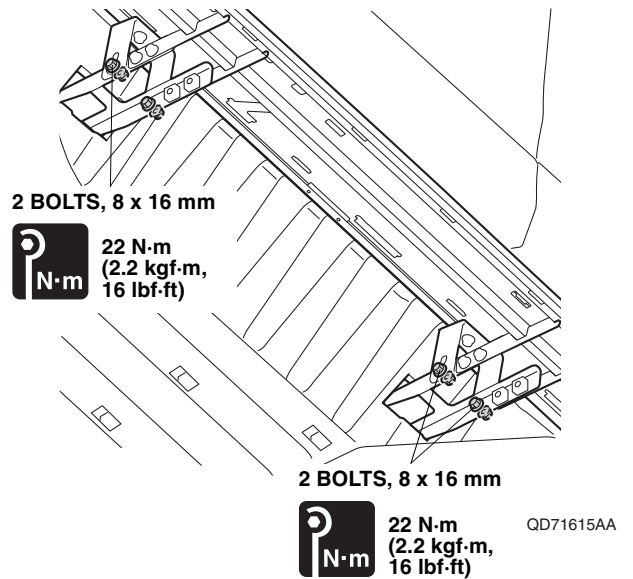

QD71615AA

62. Secure the left running board.

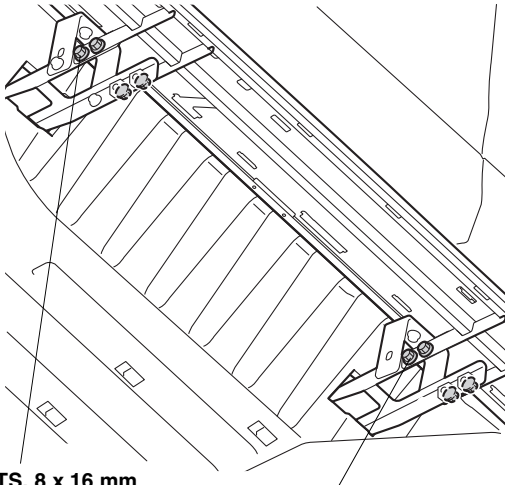

4 BOLTS, 8 x 16 mm



4 BOLTS, 8 x 16 mm



QD71616AA

63. Check the install position.

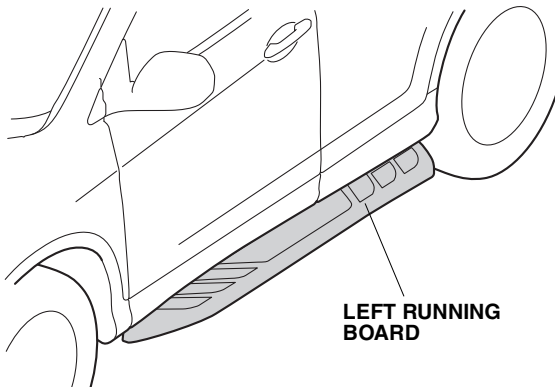
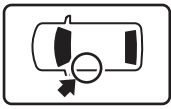

<FRONT VIEW>

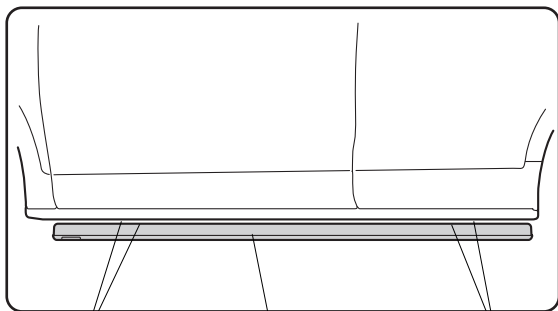

Parallel.

LEFT RUNNING BOARD

Parallel.

QD71617AA

64. Repeat same procedures for the other side.

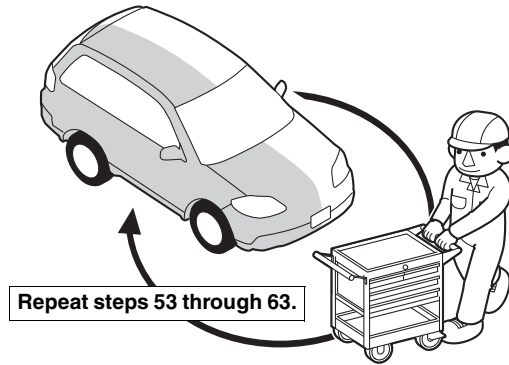

Q9D1014AM

## Check After Installation

65. Check that all parts are installed properly.

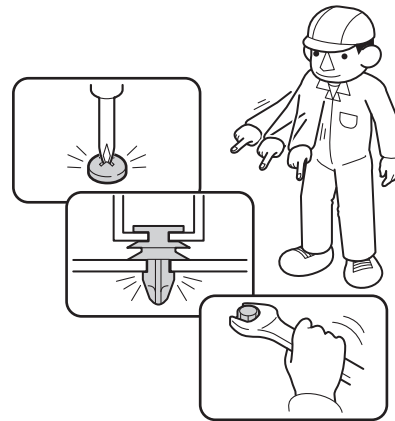

Q060705AM

## Reinstalling the All Removed Parts

66. Reinstall the all removed parts.

### NOTICE

- Be extremely careful not to damage the vehicle parts, make sure to secure the clips and the retaining tabs properly to avoid separation.

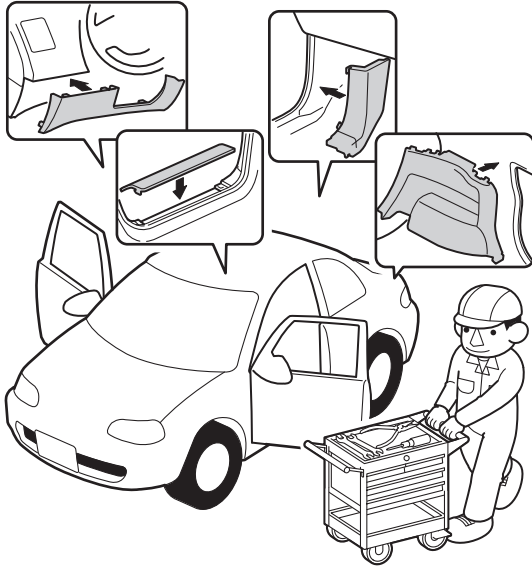

Q060703AM