

ROOF CARRIERS

CIVIC

GENERAL VIEW

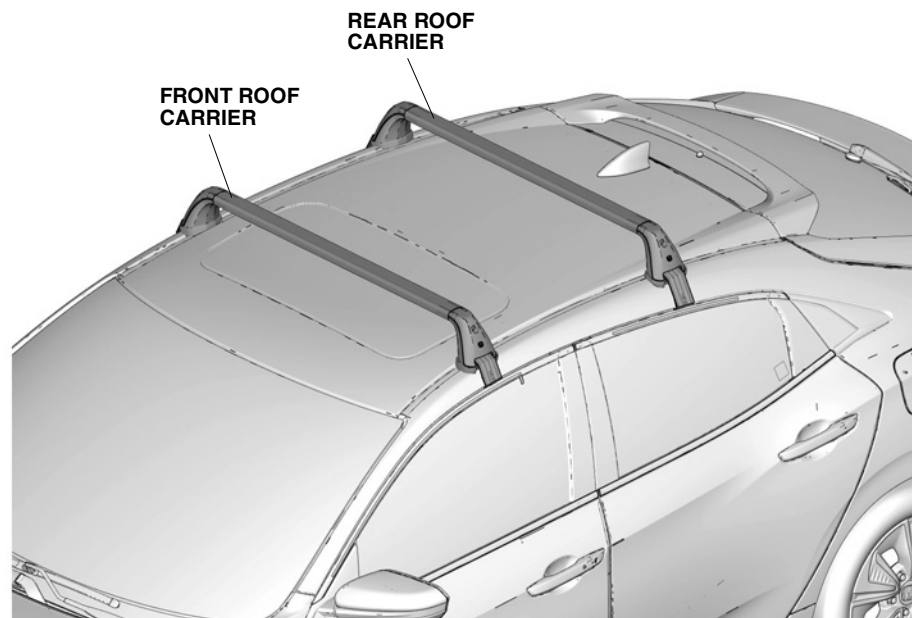

QF60101AT

FOR YOUR SAFETY (Read carefully)

Introduction of Symbol Messages

- These symbols warn you about the possible hazards and explain how to avoid them. And give you some advices.

▲ DANGER

You will be killed or seriously hurt if you do not follow the instructions.

▲ WARNING

You can be killed or seriously hurt if you do not follow the instructions.

▲ CAUTION

You can be hurt if you do not follow the instructions.

NOTICEGives advice to prevent damage to the product.
Gives helpful information or instructions to be followed in using the product.

Indicates prohibited actions.

Introduction of Icons

- These icons indicate the working place and the worker's vision.

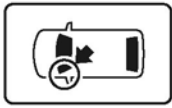

The place for the vehicle.

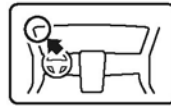

The place for the instrument panel.

- These icons indicate the necessary things for your safety and the work.



Wear eye protection.



Wear heavy gloves.



Work with an assistant.



Place the part on a blanket.



Remove any burrs.



Use the touch-up paint and dry.



Keep the parts and give it to the customer.
(Not use)



Press firmly.



Tighten by specified torque.



Work perpendicularly.



Clean with the contact cleaner.

Safety: General









- Be careful not to damage the vehicle and the parts.
- The illustrations may differ a little from the actual accessories for the design change of the vehicle.

Safety: For the Accessory

- Do not perform installation work and attaching work at the place where gets the direct rays of the sun or the dust appears.
- Always install these accessories at the ambient air temperature 15°C (60°F) or above.
- Heat the accessories and bonding surfaces if the ambient air temperature is below 15°C (60°F).
- Attach the accessories by pressing it firmly with the palm of your hand. Be careful not to damage the accessories and the vehicle parts.
- Carefully place the double-sided adhesive tape on the proper position. Once the double-sided adhesive tape touches the surface, do not try to detach and relocate it. If you attempt to move after it touches the surface, you will damage the part before the adhesive will give way.
- Not to wash the vehicle for 24 hours to allow the adhesive to cure.

PARTS LIST

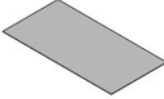
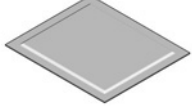
Roof Carrier Kit

Front roof carrier (mark: FRONT LEFT)	Rear roof carrier (mark: REAR LEFT)	Right front cushion (mark: FRONT/ RIGHTHAND)	Left front cushion (mark: FRONT/ LEFTHAND)
			
Right rear cushion (mark: REAR/ RIGHTHAND)	Left rear cushion (mark: REAR/ LEFTHAND)	Label	Cleaner
			
Allen wrench	Keys (2)		
			

TOOLS AND SUPPLIES REQUIRED

- Ruler

INSTALLATION

Installing the Roof Carriers

1. Remove the covers.

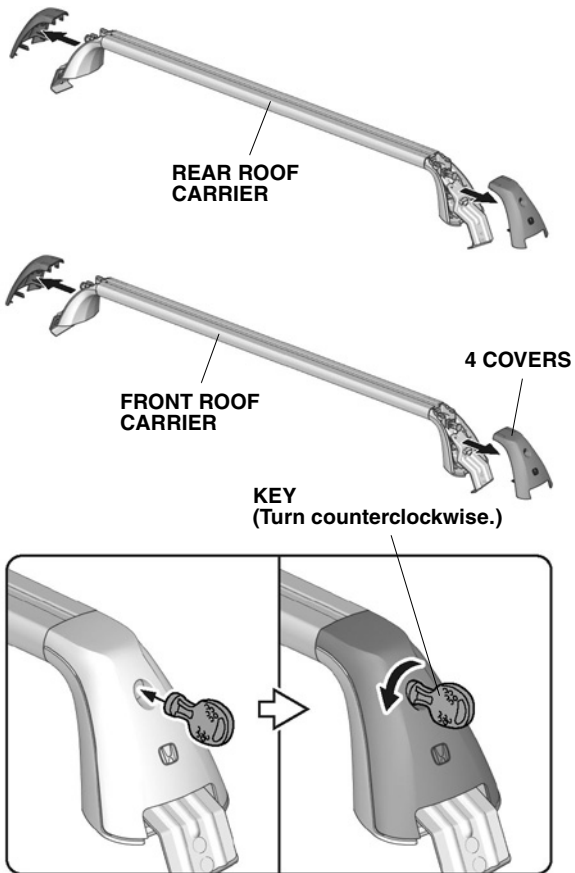

QDN0502AJ

2. Install the cushions.

NOTICE

- Make sure to check the identification mark and the part number before installation.

PART NUMBERS

Model	Rack	Right	Left
CIVIC	Front	124318	124317
	Rear	124320	124319

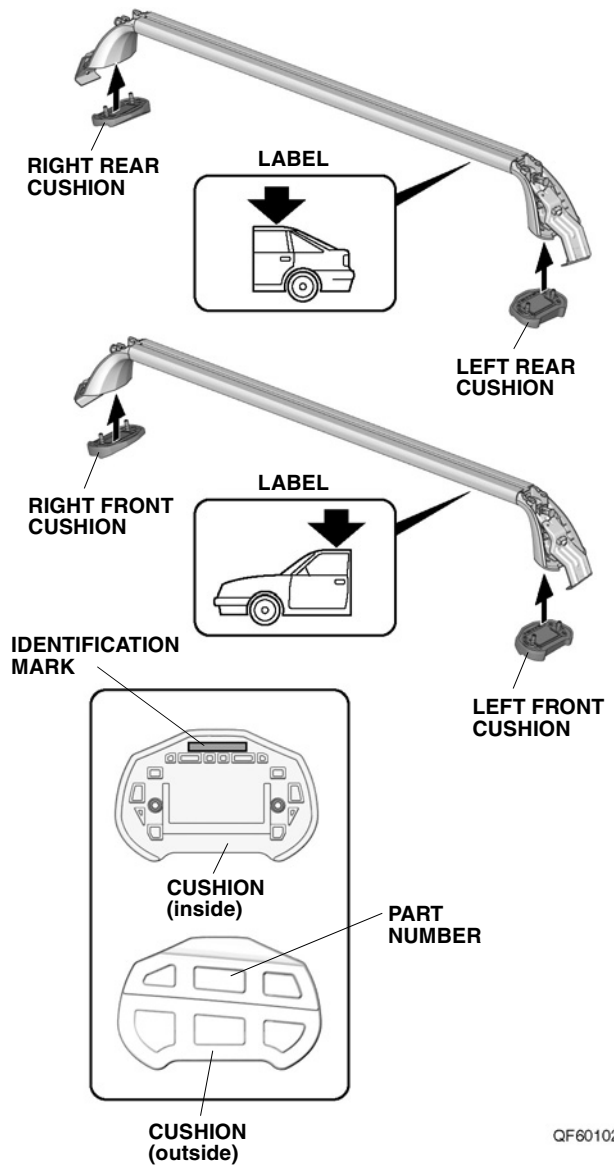

QF60102BT

3. Open all the doors.
4. Clean the vehicle panel.

NOTICE
• Dry thoroughly.

5. Attach the labels.
6. Repeat same procedures for the other side.

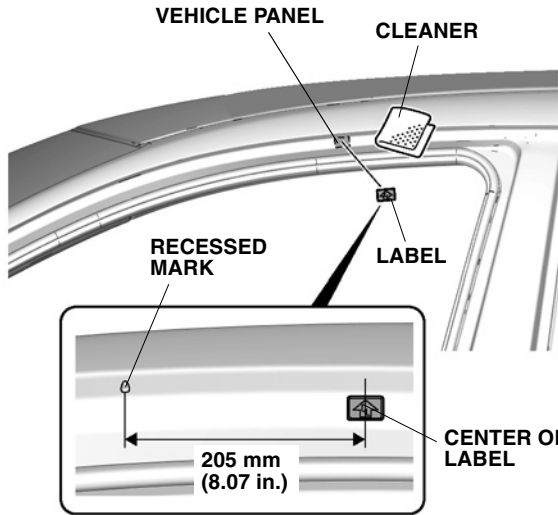

QF60110AH

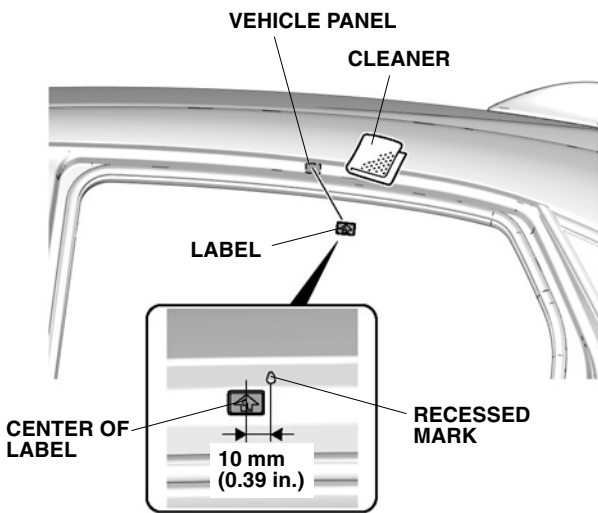
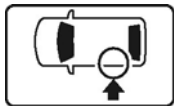

QF60111AH

7. Position the roof carriers.

NOTICE
• Make sure to check the label before installation.

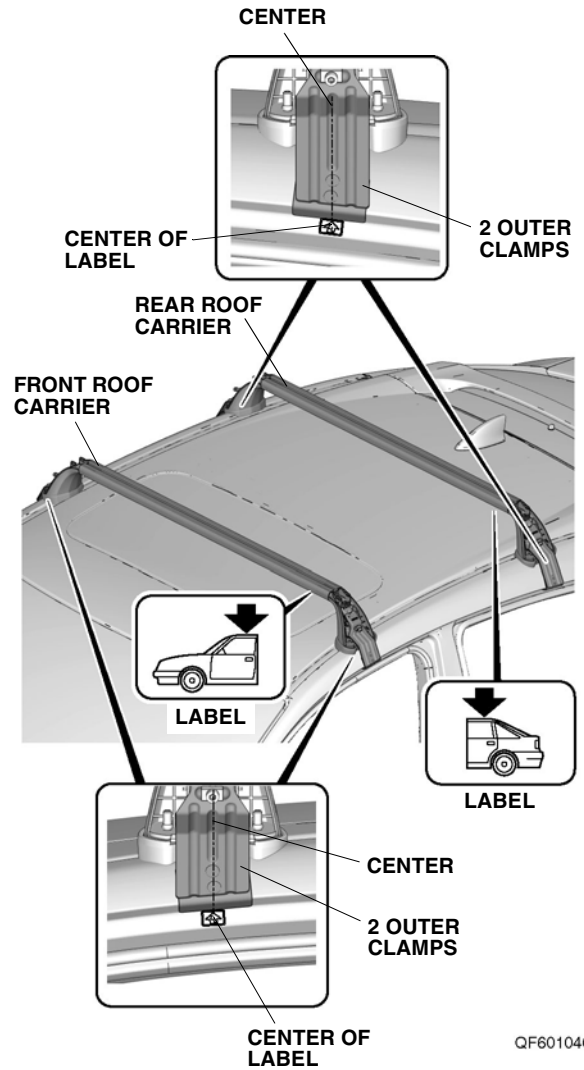

QF60104CT

8. Secure the roof carriers.

NOTICE

- Tighten the right and left socket bolts alternately to even the pressure.

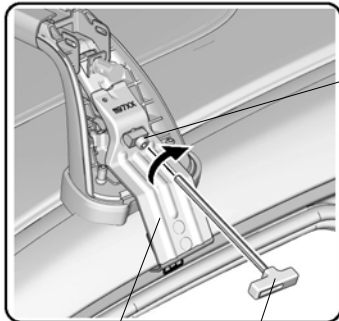
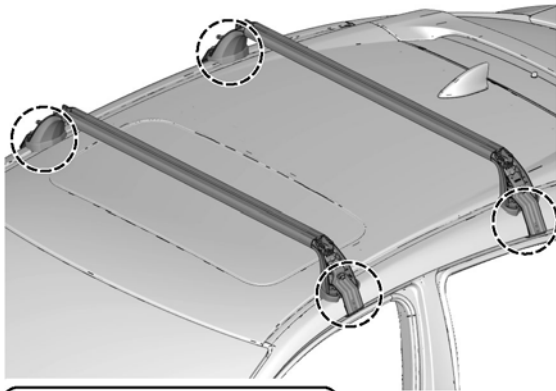
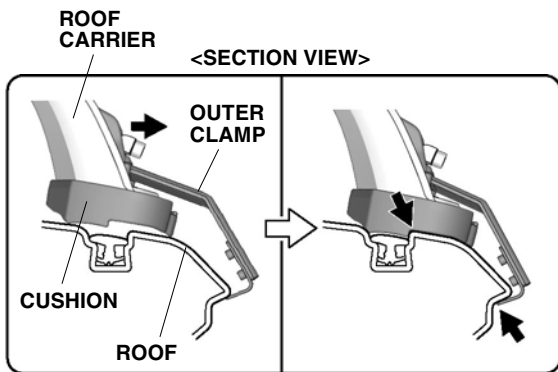

4 SOCKET BOLTS

4 OUTER CLAMPS

ALLEN WRENCH
(Turn clockwise.)

QF60105CT

9. Check the roof carriers.

NOTICE

- Rock the roof carriers in all directions to check if they are installed securely without play or rattle.
- If found with abnormal play or rattle, retighten the socket bolts, or reinstall the roof carriers as described in these installation instructions.

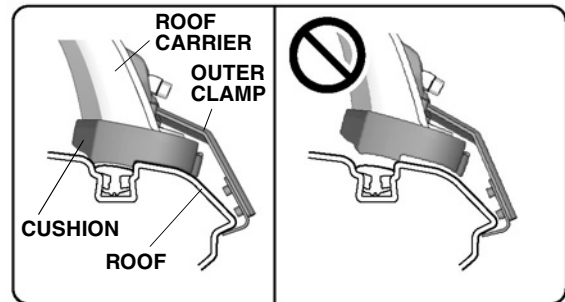
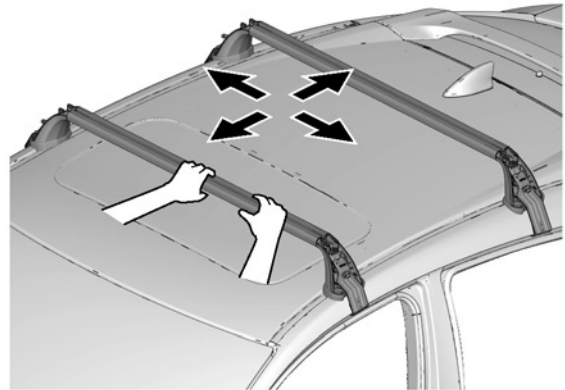

<SECTION VIEW>

QF60106AT

10. Install the covers.

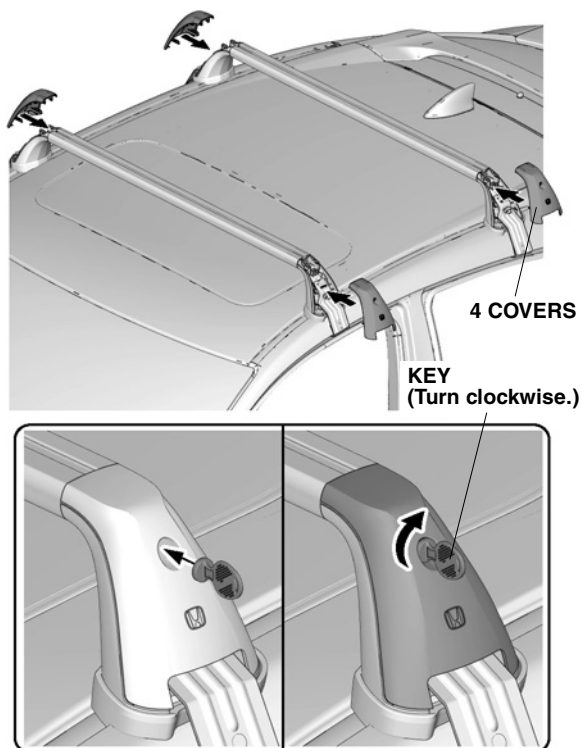

QF60107AT

11. Check that all parts are installed properly.
(End of installation)

Please pass your customer the following things.

- 2 Keys
- Allen wrench

Please give your customer a copy of this page.

Use and Care

- Write down the key number in case the key is lost or stolen.

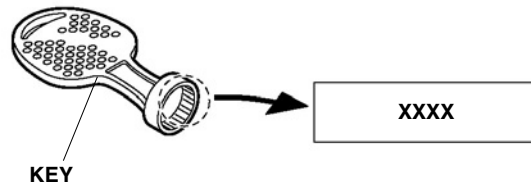

QF60108AT

- **With 16" and 17" wheel models:**

The maximum load for the roof carrier is 45 kg (99 lbs) (includes the weight of roof carrier which is 5 kg (11 lbs)).

- **With 18" wheel models:**

The maximum load for the roof carrier is 35 kg (77 lbs) (includes the weight of roof carrier which is 5 kg (11 lbs)).

- Do not overload. Make sure to fasten the load so that it cannot come loose or cause damage. Be careful to secure the load against movement in driving direction or sideways movements.
When loading the roof carrier, make sure that the weight is evenly distributed and that the center of gravity of the load is kept as low as possible. If small and very heavy loads have to be transported, make sure that they are placed on one side of the carrier and not into the middle.
- For safety reasons, the load may not protrude from the vehicle outline.
- Before driving, make sure that all fastening parts are fixed according to regulations. Please check if the load is fastened properly. Stop after a short drive to check screw connections and especially the foot attachments, then check every time before driving.
- Please pay attention to the altered behavior to the vehicle (due to side wind sensitivity, when driving in bends and when braking) when you drive a mounted (loaded) roof carrier. To safeguard other road users, and in order to reduce air resistance, the roof carrier should be dismantled if it is not used.
- Obey local laws and regulations.

Advice for your own security

- **IMPORTANT:** This roof carrier is especially designed for the specified vehicle. Please therefore check with your retailer which type of roof carrier is needed when changing your vehicle.
Test reports from the automotive industry and trade journals prove that when objects with large surfaces are transported, (e.g. surfboards, ski/transport boxes) the roof of the vehicle will be additionally strained due to the strongly increased air resistance. (When transporting a surfboard, the bow should point downwards in the driving direction.)
The driving characteristics change as well; therefore we recommend you to adjust your speed accordingly.
Do not put the vehicle through an automatic vehicle wash when the roof carrier is mounted.

The manufacturer takes no responsibility for damage caused by an incorrectly fitted roof carrier.

- **READ VEHICLE OWNER'S MANUAL CAREFULLY.**

The vehicle Owner's Manual has important safety and operation information.

These instructions should be considered a permanent part of the vehicle and should remain with the vehicle if sold.