

BUMPER MOLDINGS	<i>Honda e</i>
-----------------	----------------

GENERAL VIEW

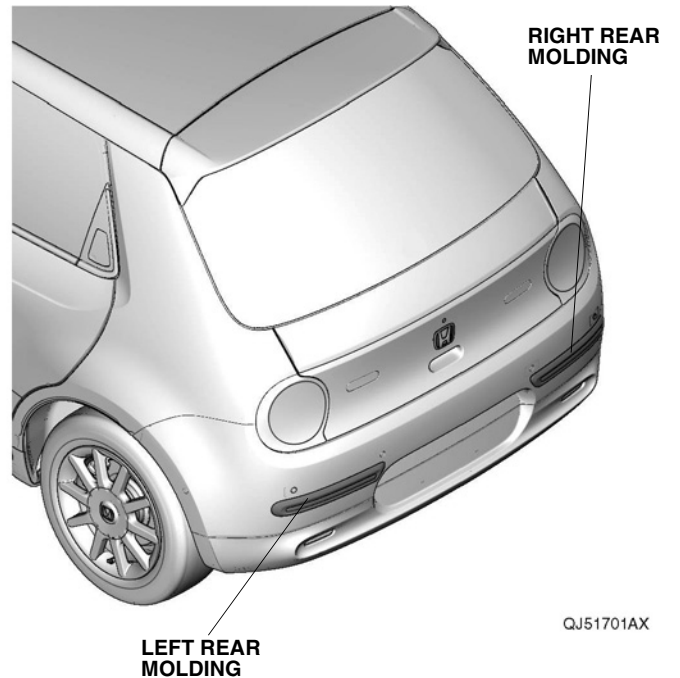
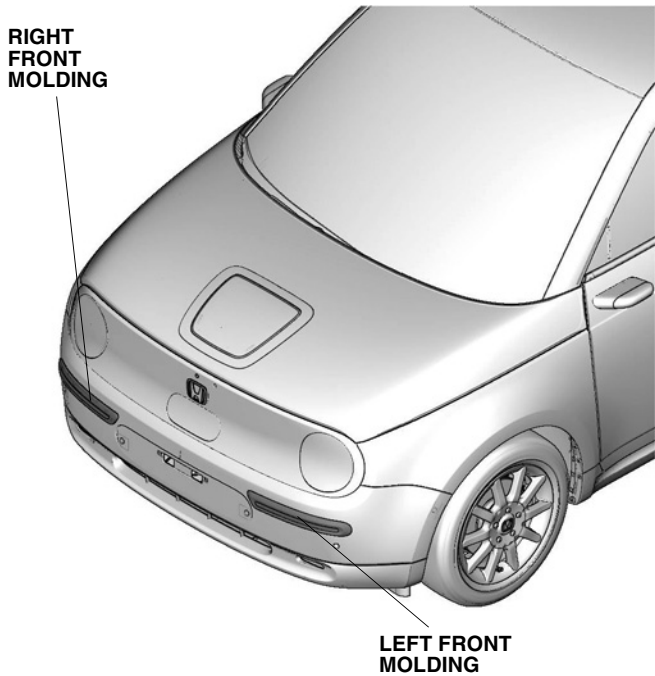

QJ51701AX

FOR YOUR SAFETY (Read carefully)

Introduction of Symbol Messages

- These symbols warn you about the possible hazards and explain how to avoid them. And give you some advices.

⚠ DANGER

You will be killed or seriously hurt if you do not follow the instructions.

⚠ WARNING

You can be killed or seriously hurt if you do not follow the instructions.

⚠ CAUTION

You can be hurt if you do not follow the instructions.

NOTICE

Gives advice to prevent damage to the product.
Gives helpful information or instructions to be followed in using the product.



Indicates prohibited actions.

Introduction of Icons

- These icons indicate the working place and the worker's vision.

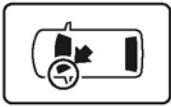

The place for the vehicle.

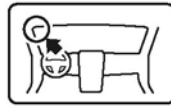

The place for the instrument panel.

- These icons indicate the necessary things for your safety and the work.



Wear eye protection.



Wear heavy gloves.



Work with an assistant.



Place the part on a blanket.



Remove any burrs.



Use the touch-up paint and dry.



Keep the parts and give it to the customer.
(Not use)



Press firmly.



Tighten by specified torque.



Work perpendicularly.



Clean with the contact cleaner.

Safety: General





- Be careful not to damage the vehicle and the parts.
- The illustrations may differ a little from the actual accessories for the design change of the vehicle.

Safety: For the Accessory

- **Do not perform installation work and attaching work at the place where gets the direct rays of the sun or the dust appears.**
- **Always install these accessories at the ambient air temperature 15°C (60°F) or above.**
- **Heat the accessories and bonding surfaces if the ambient air temperature is below 15°C (60°F).**
- **Attach the accessories by pressing it firmly with the palm of your hand. Be careful not to damage the accessories and the vehicle parts.**
- **Carefully place the double-sided adhesive tape on the proper position. Once the double-sided adhesive tape touches the surface, do not try to detach and relocate it. If you attempt to move after it touches the surface, you will damage the part before the adhesive will give way.**
- **Not to wash the vehicle or moisten it for 24 hours to allow the adhesive to cure.**

PARTS LIST

Bumper Moldings Kit

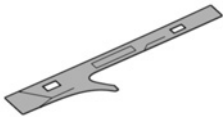
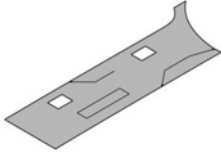
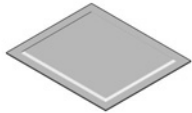
Left front molding (identification mark: FR-L)	Right front molding (identification mark: FR-R)	Left rear molding (identification mark: RR-L)	Right rear molding (identification mark: RR-R)
			
Front template	Rear template	Cleaners (4)	
			

Tools and Supplies Required

- Masking tape
- Tape

INSTALLATION

Installing the Front Bumper Moldings

1. Secure the front template.

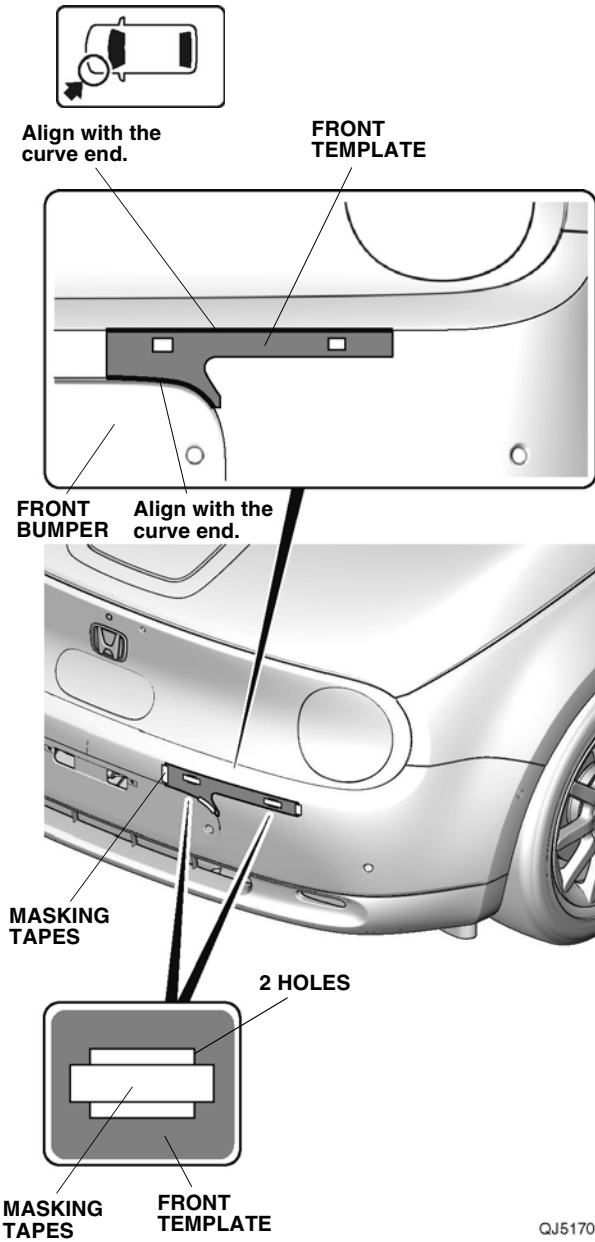

QJ51702CX

2. Clean the attaching area.

NOTICE

- Dry thoroughly.

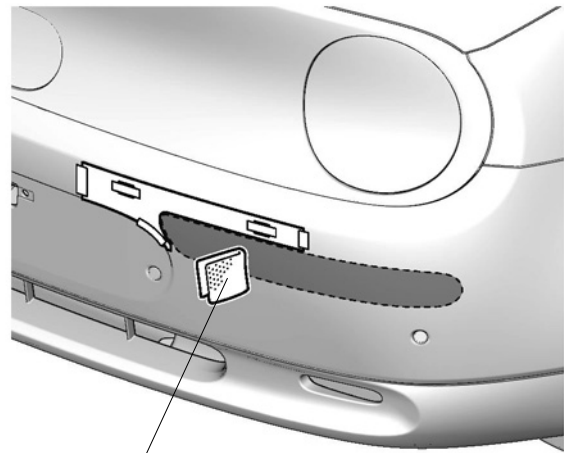

CLEANER

QJ51703BX

3. Temporarily attach the adhesive backings.

NOTICE

- Make sure to check the identification mark and the installation position before installation.

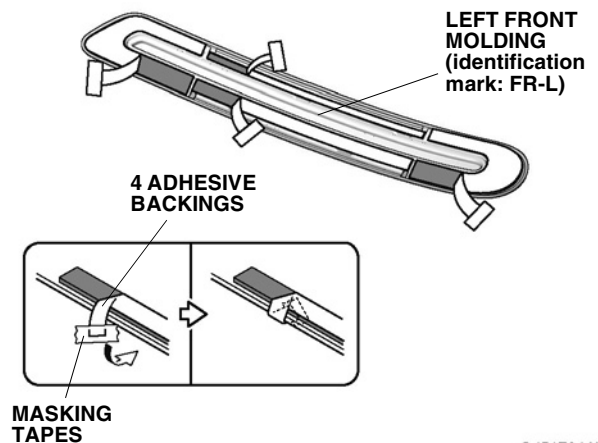

QJ51704AX

4. Align the left front molding.

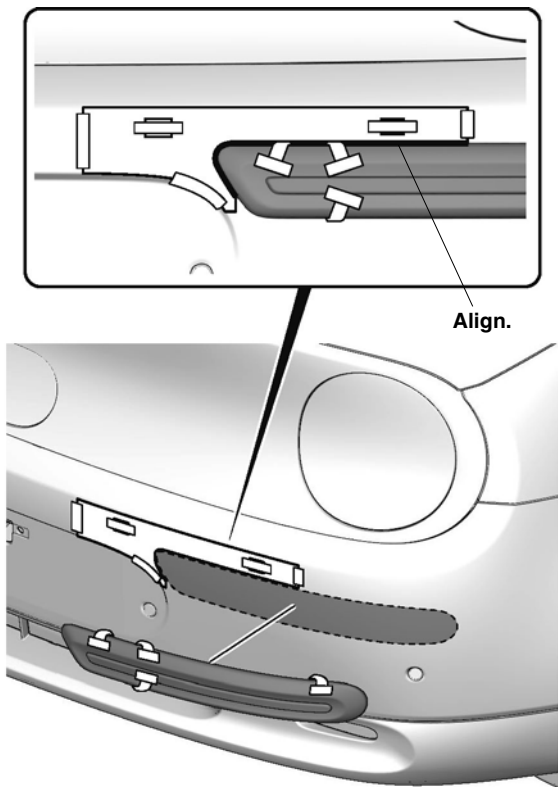

QJ51705BX

5. Remove the front template.

6. Loosely secure the left front molding.

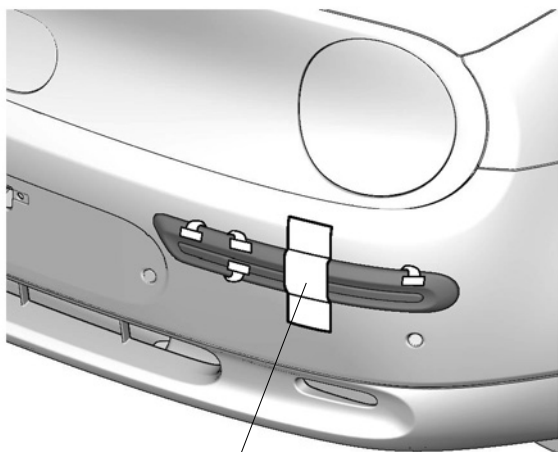

QJ00101AA

7. Secure the left front molding.

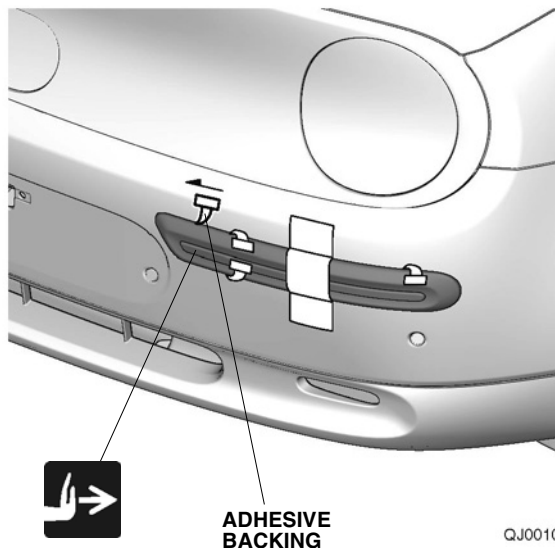

8. Remove the tape.

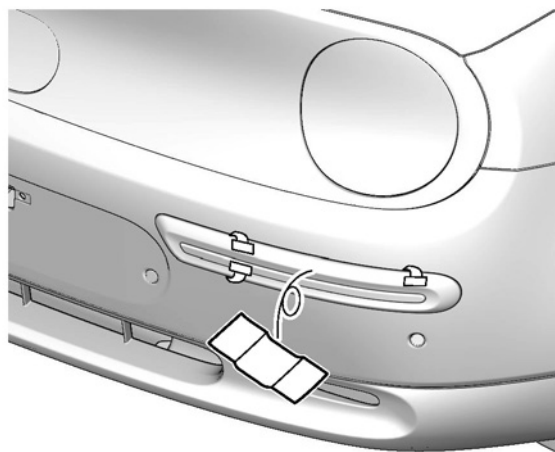

QJ00103AA

9. Secure the left front molding.

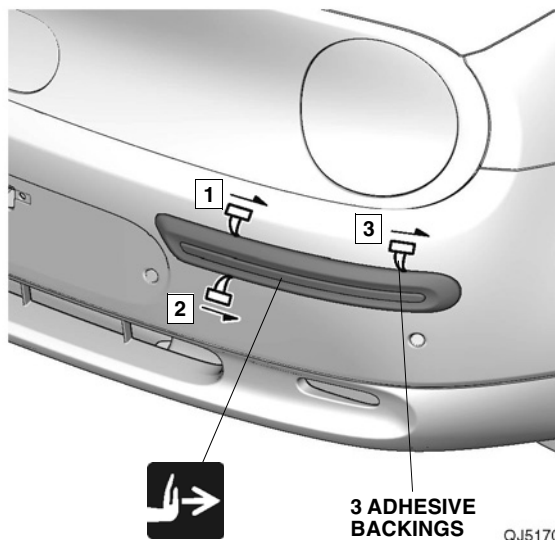

QJ51706BX

10. Flip the front template.
11. Repeat same procedures for the other side.

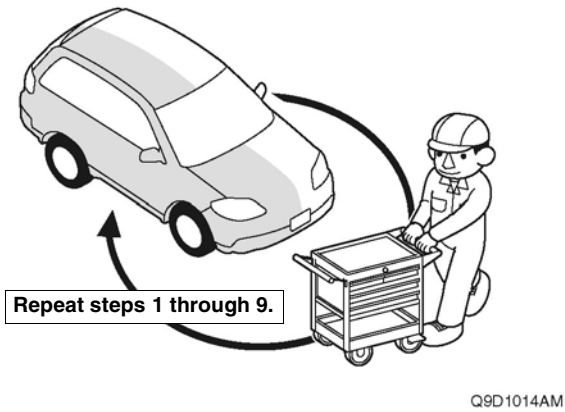

Installing the Rear Bumper Moldings

12. Secure the rear template.

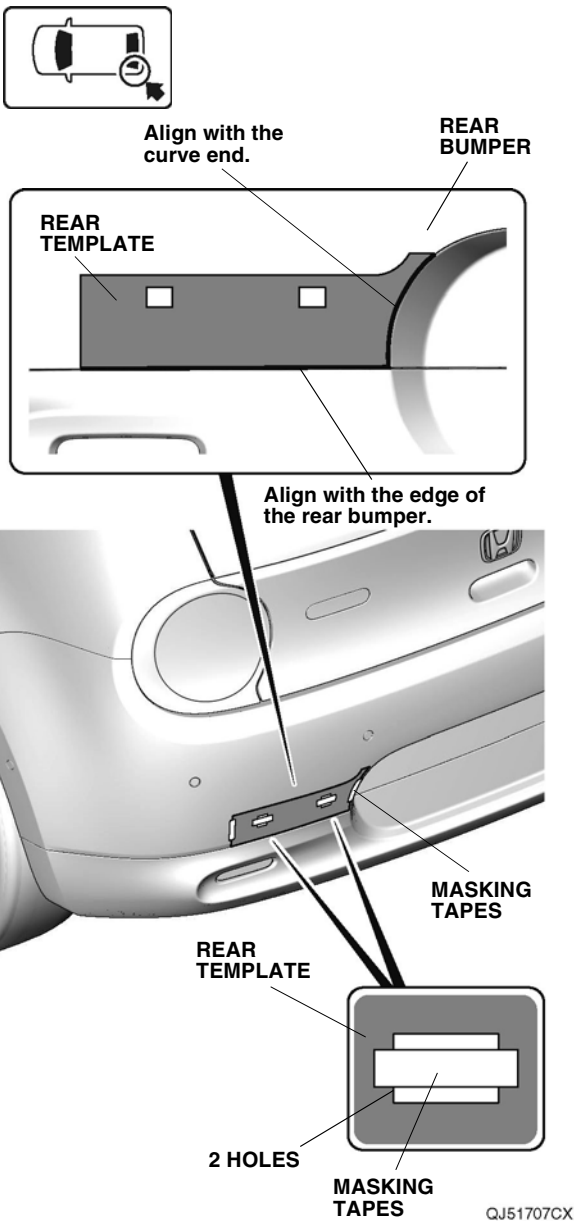

13. Clean the attaching area.

NOTICE

- Dry thoroughly.

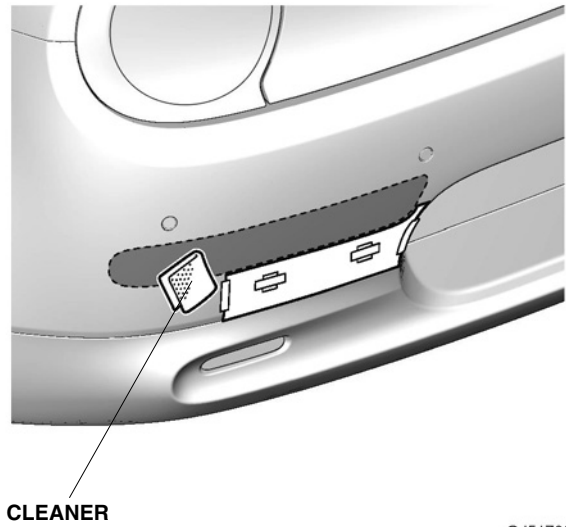

14. Temporarily attach the adhesive backings.

NOTICE

- Make sure to check the identification mark and the installation position before installation.

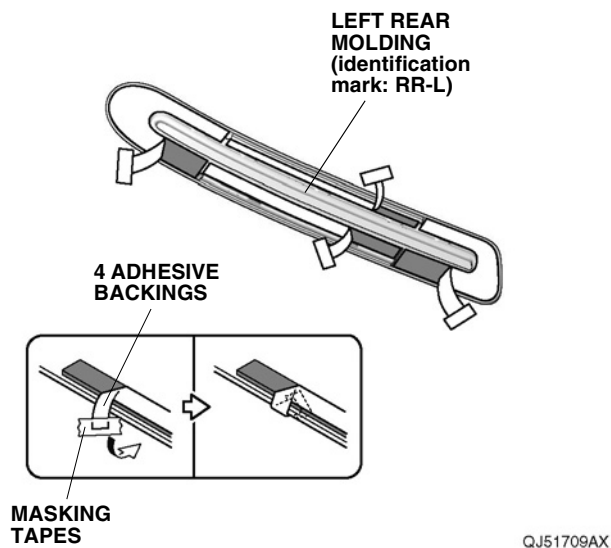

15. Align the left rear molding.

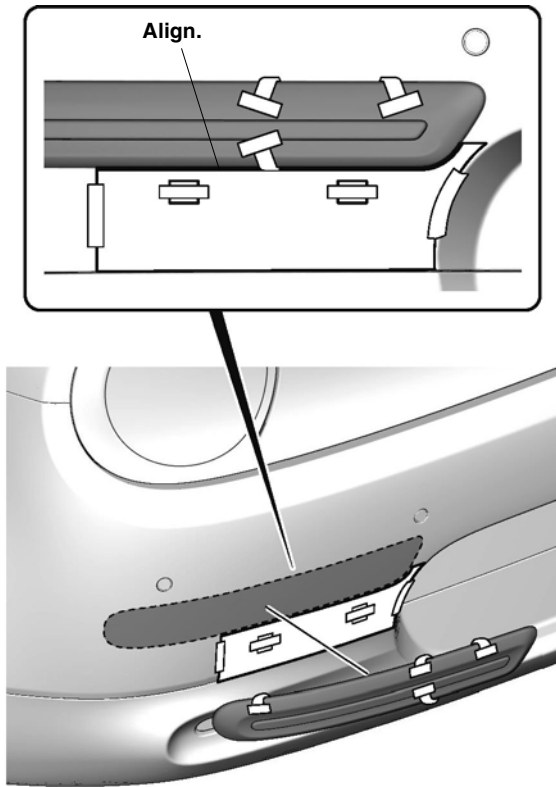

QJ51710BX

16. Remove the rear template.

17. Loosely secure the left rear molding.

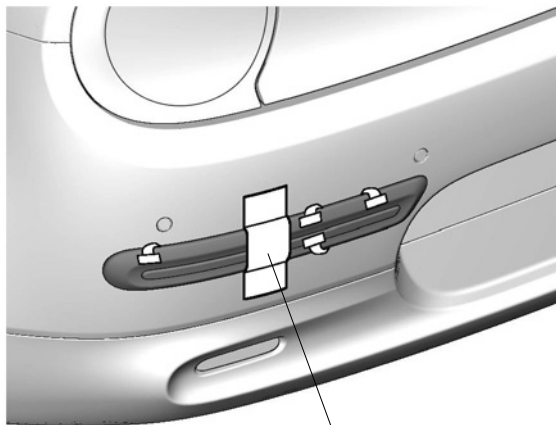

QJ00104AA

18. Secure the left rear molding.

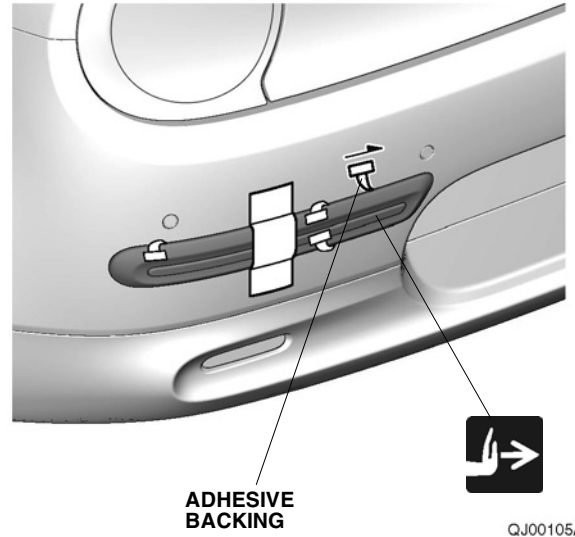

19. Remove the tape.

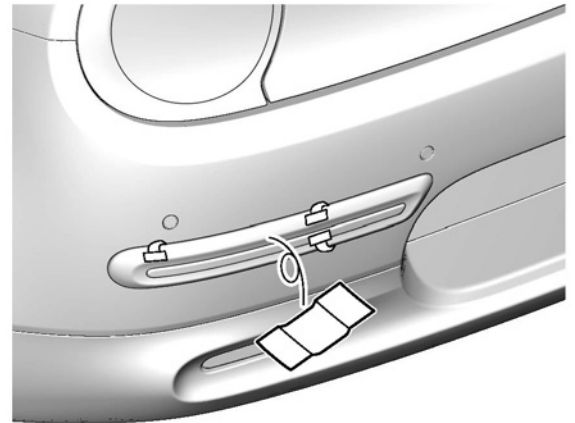

QJ00106AA

20. Secure the left rear molding.

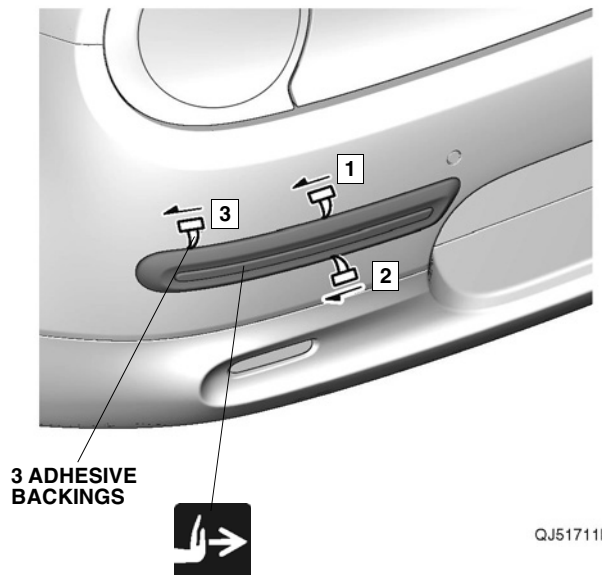

21. Flip the rear template.
22. Repeat same procedures for the other side.

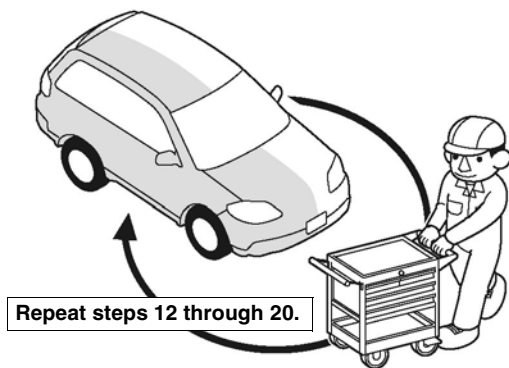

Q9D1014AM

23. Check that all parts are installed properly.
(End of installation)