

MUD GUARDS

JAZZ

GENERAL VIEW

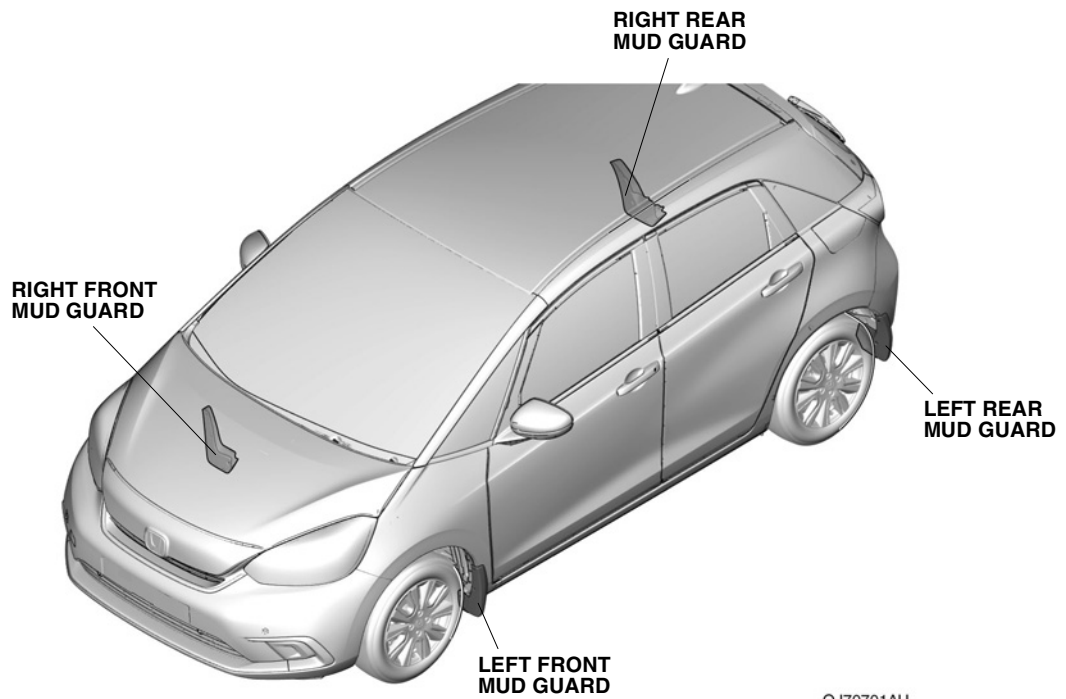

FOR YOUR SAFETY (Read carefully)

Introduction of Symbol Messages

- These symbols warn you about the possible hazards and explain how to avoid them. And give you some advices.

⚠ DANGER

You will be killed or seriously hurt if you do not follow the instructions.

⚠ WARNING

You can be killed or seriously hurt if you do not follow the instructions.

⚠ CAUTION

You can be hurt if you do not follow the instructions.

NOTICEGives advice to prevent damage to the product.
Gives helpful information or instructions to be followed in using the product.

Indicates prohibited actions.

Introduction of Icons

- These icons indicate the working place and the worker's vision.

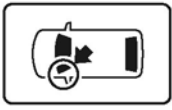

The place for the vehicle.

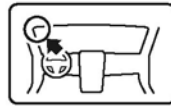

The place for the instrument panel.

- These icons indicate the necessary things for your safety and the work.



Wear eye protection.



Wear heavy gloves.



Work with an assistant.



Place the part on a blanket.



Remove any burrs.



Use the touch-up paint and dry.



Keep the parts and give it to the customer.
(Not use)



Press firmly.



Tighten by specified torque.



Work perpendicularly.



Clean with the contact cleaner.

Wire Harness Routing Precaution

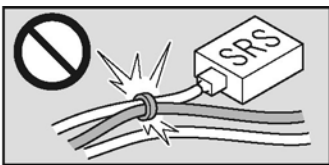

Do not clamp the accessory harness and SRS harness together.



Connect the connectors and terminals securely until they lock.

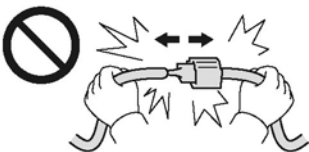

Do not pull the harness to disconnect the connectors.

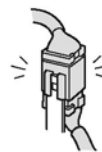

Reinstall the connectors to the original positions if they are removed.

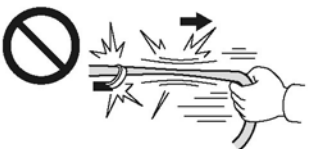

Do not pull the harness strongly.



Secure the accessory harness to the specified position, not to hang down.



Do not pinch the harness with the parts.

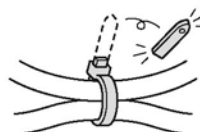

Cut off the excess of the wire ties.

Safety: General

- Observe all safety notes and precautions described in the Service Manual in addition to those described in this Installation Instructions. Be extremely careful for your safety and safety of others particularly.
- Be careful not to damage the vehicle and the parts.
- Be extremely careful to the handling of the retaining tabs and clips particularly.
- Note the locations of the parts before removing them so that they can be reinstalled in their original positions properly.
- The illustrations may differ a little from the actual accessories for the design change of the vehicle.

Safety: For Electric Parts

- Do not perform the installation of the accessories with having connected negative cable of the battery.

Safety: For the Accessory

- **Always use the parts and tools specified in the installation instructions.**

PARTS LIST

Mud Guard Kit

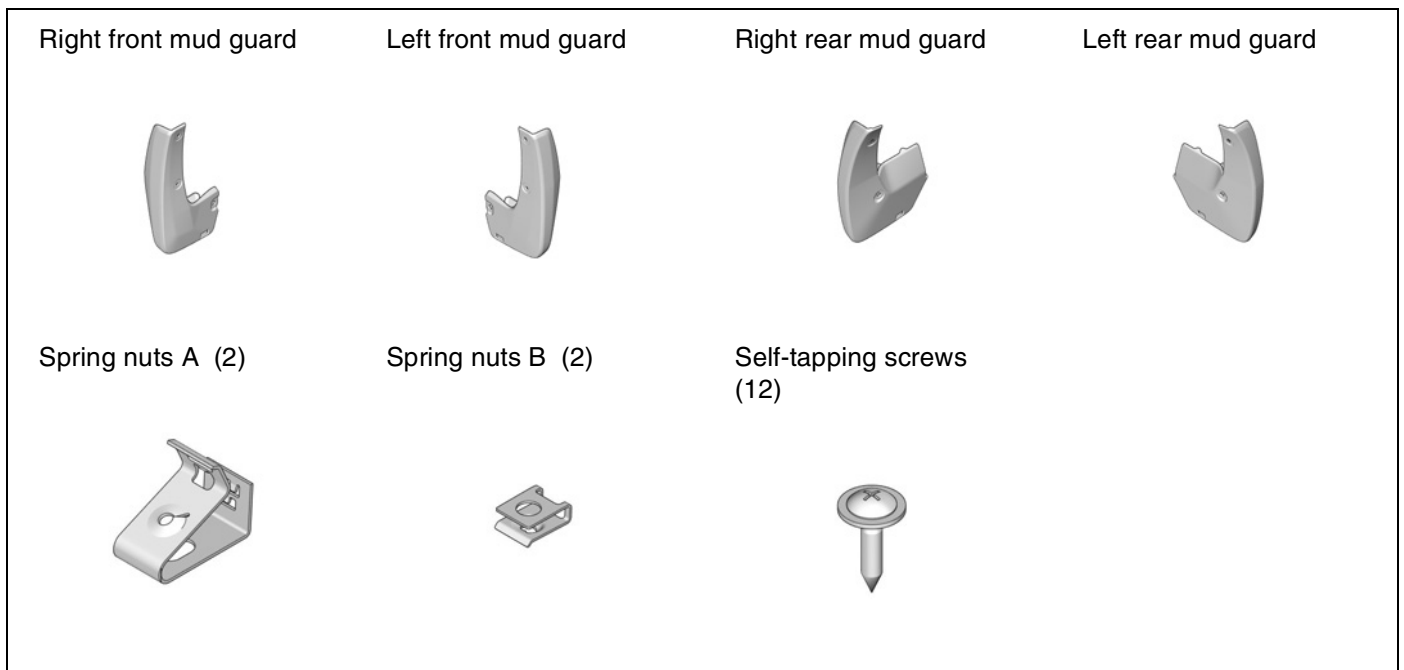

TOOLS AND SUPPLIES REQUIRED

- Phillips screwdriver
- 5 mm Hex wrench
- Tape
- 10 mm Socket
- Drill
- Eye protection (face shield, safety goggles, etc.)
- Ratchet
- Stubby Phillips screwdriver
- Blanket
- 10 mm Open end wrench
- Handy remover
- Pliers
- Utility knife
- Pushpin
- File
- 3 mm, 6 mm, 8 mm, and 10 mm Drill bits

INSTALLATION

Installing the Front Mud Guards

1. Turn the steering wheel fully counterclockwise.
2. Pierce the clips.

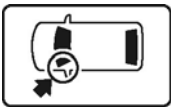

3 CLIPS

<SECTION VIEW>

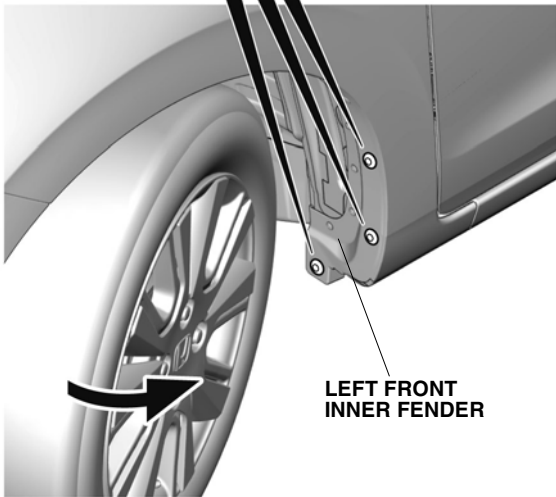
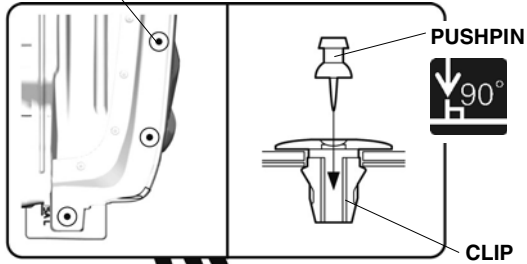

QJ70702AU

3. Install the left front mud guard.

NOTICE

- Make sure that there is no gap between the mud guard and vehicle.
- Make sure that the mud guard is properly installed.

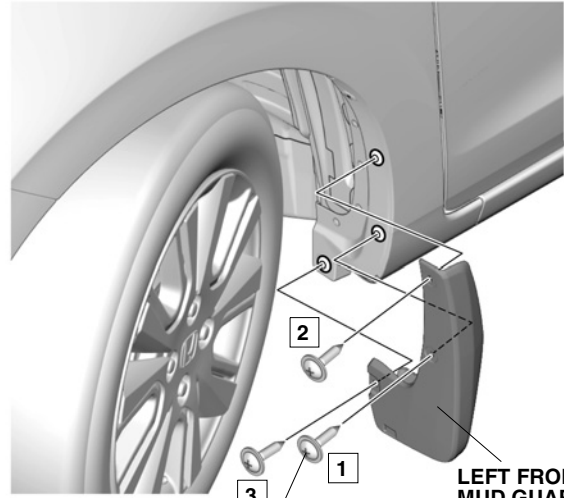

3 SELF-TAPPING
SCREWS

QJ70703BU

4. Turn the steering wheel fully clockwise.
5. Repeat same procedures for the other side.

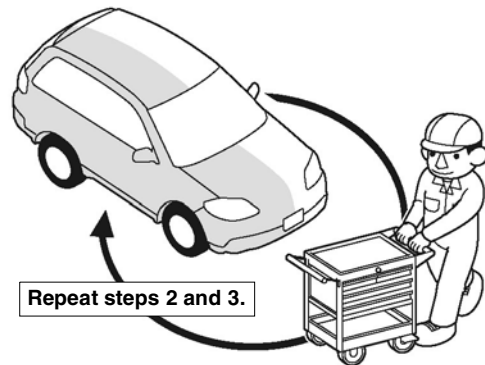

Q9D1014AM

Disconnecting the Battery Cable

6. Perform the works before disconnecting the negative cable from the battery as shown below.
7. Make sure if you have the anti-theft code for the audio/navigation system. Record some settings of the vehicle if necessary.
8. Disconnect the negative cable from the battery.

NOTICE

- For Hybrid vehicle, make sure not to disconnect the negative cable from the battery three minutes after turning the engine switch to OFF.

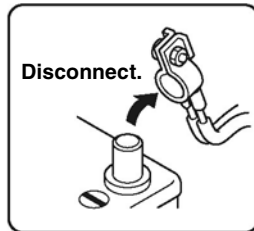
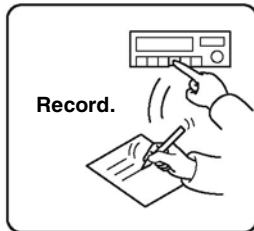
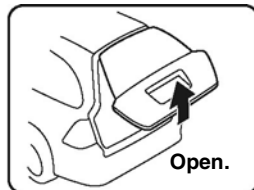
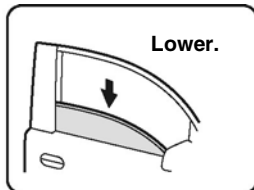

QCD0504BM

Installing the Rear Mud Guards

9. Attach the tapes to protect the vehicle.

NOTICE

- Do not remove the tapes until after the reinstallation.

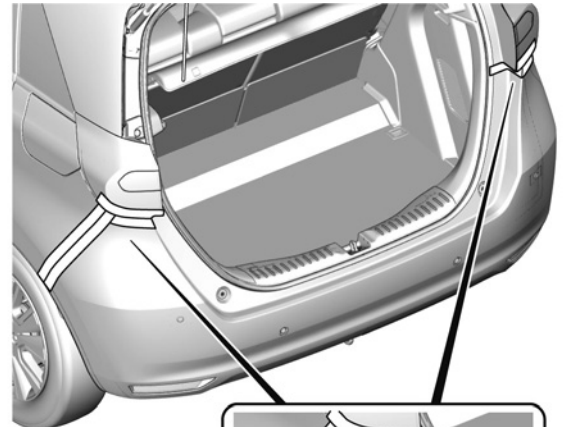
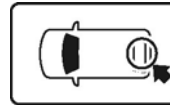

REAR FENDER

TAPES

REAR BUMPER

QJ70901AU

10. Remove the covers, hex bolts, clips, and self-tapping screws.

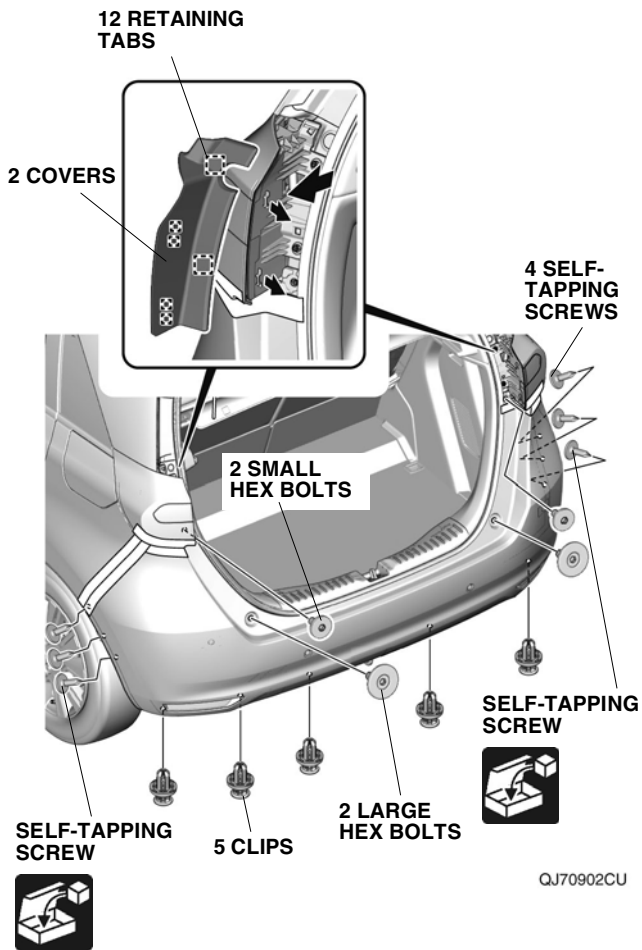

11. Release the retaining tabs.

NOTICE

- Remove the retaining tabs in order from outside.
- Make sure to remove retaining tabs in the correct orientation.

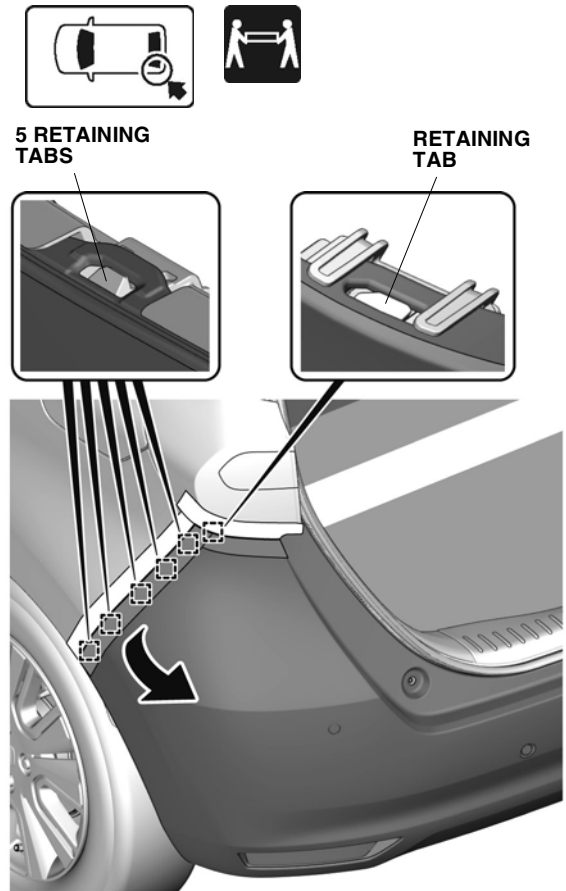

12. Repeat step 11 for the other side.

13. Remove the rear bumper.

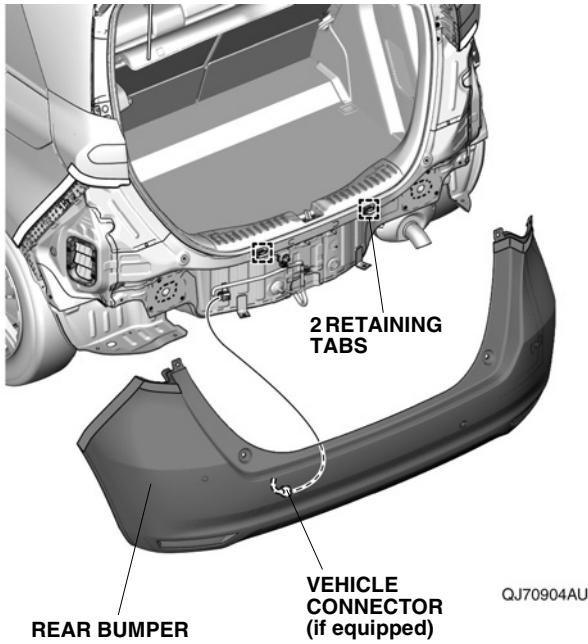
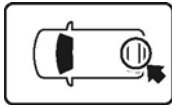

14. Remove the left rear fender cover.

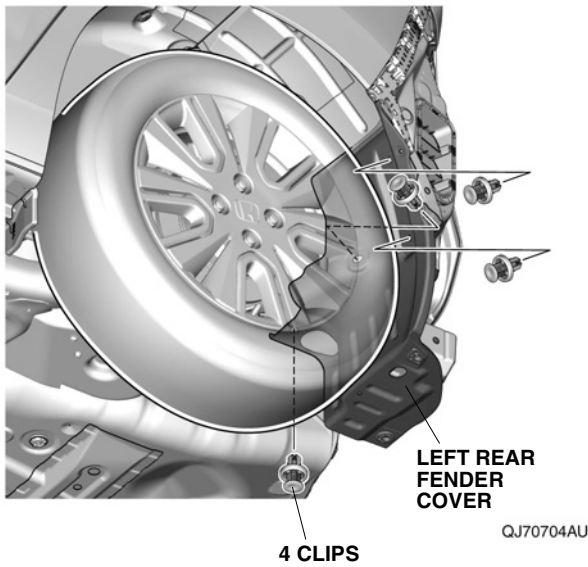
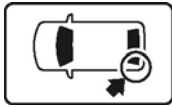

15. Cut the left rear fender cover.

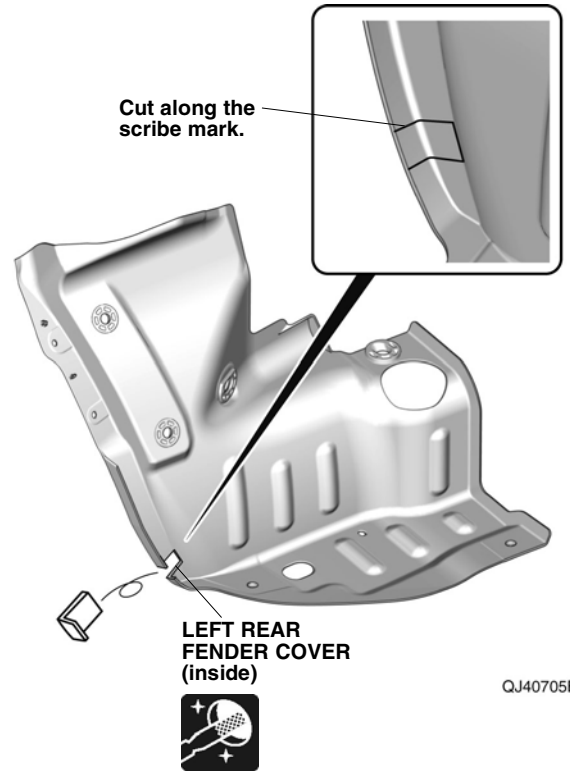

16. Pierce the left rear fender cover.

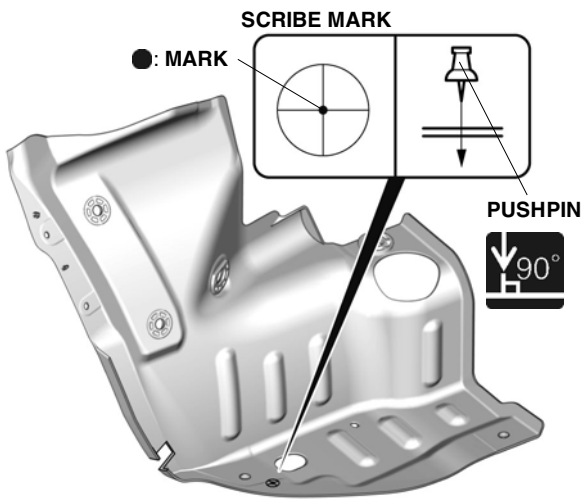

QJ40706BU

17. Drill the left rear fender cover.

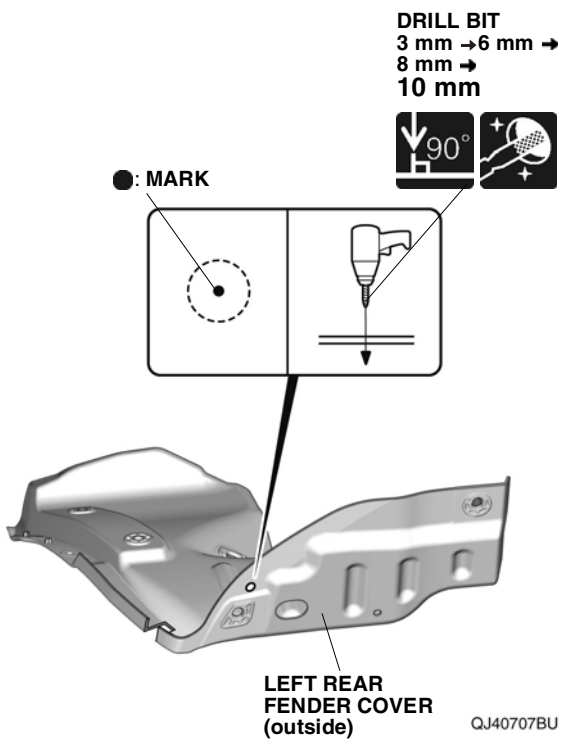

18. Reinstall the left rear fender cover.

19. Remove the right rear fender cover.

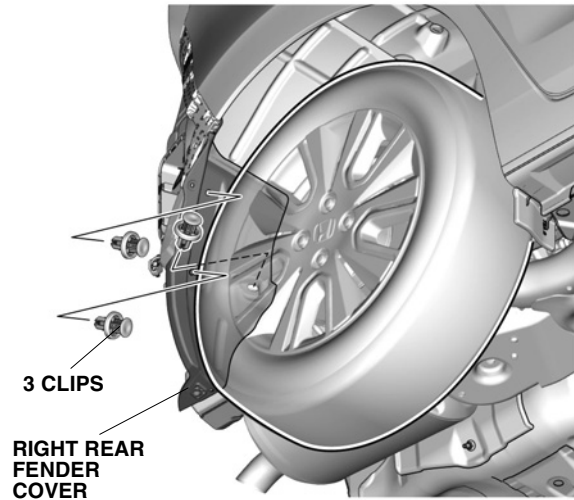
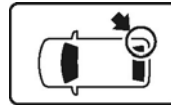

20. Cut the right rear fender cover.

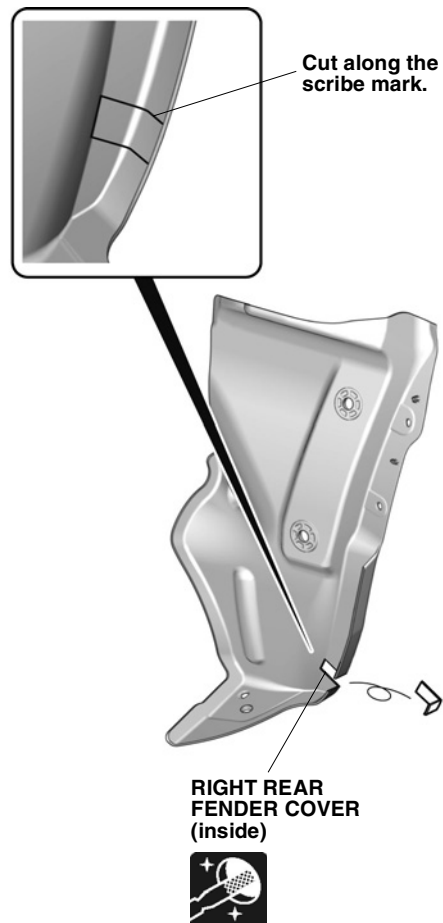

21. Pierce the right rear fender cover.

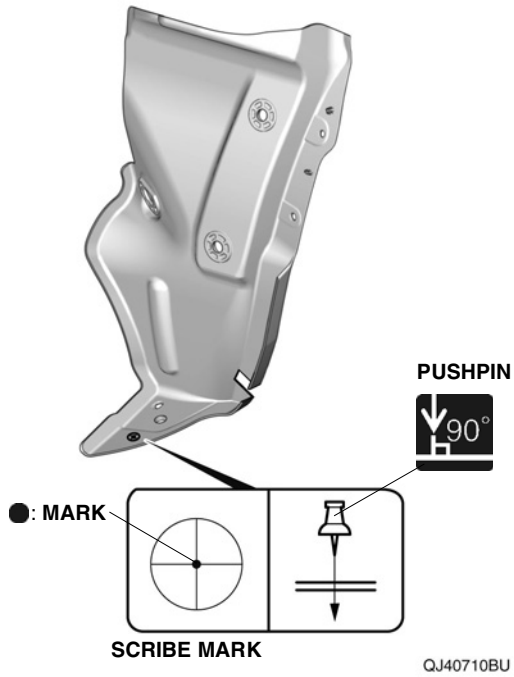

22. Drill the right rear fender cover.

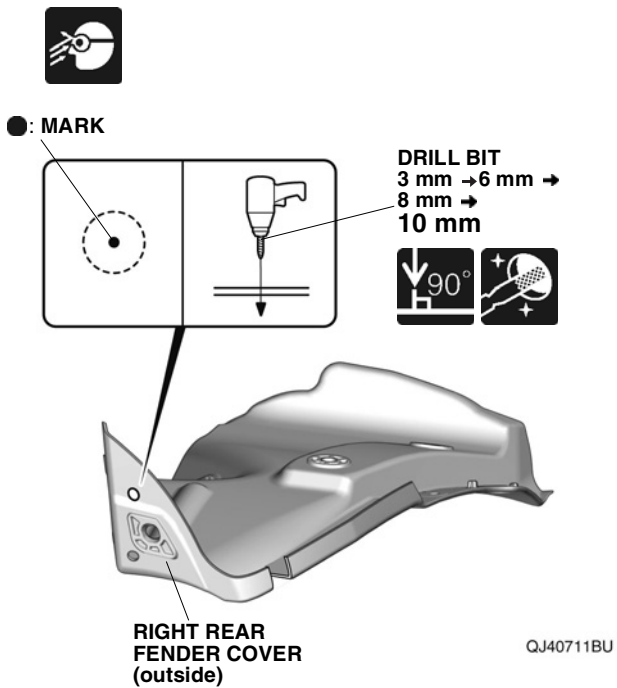

23. Reinstall the right rear fender cover.

24. Install the spring nuts A.

NOTICE

- Make sure to install the spring nuts in the correct orientation.

25. Tape the spring nuts A.

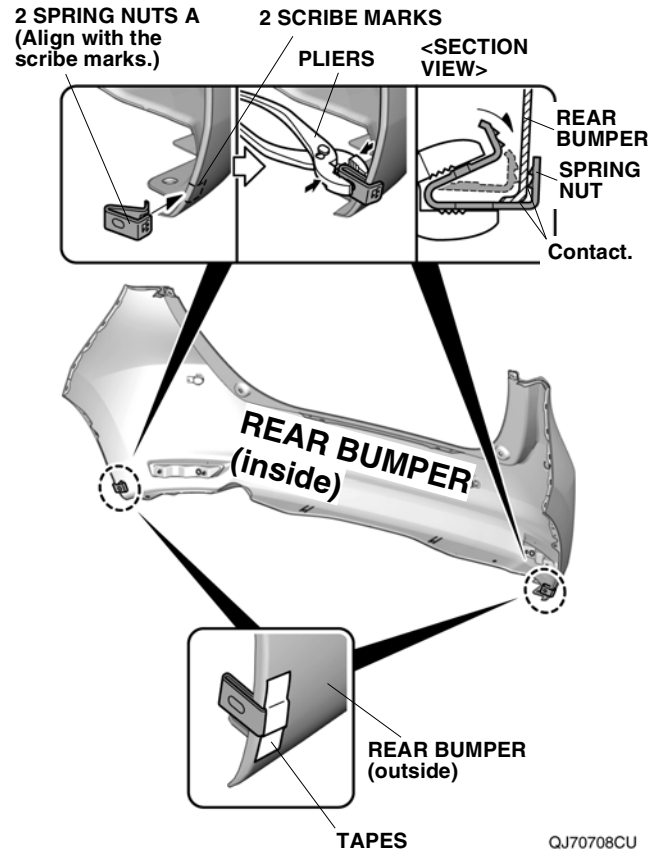

26. Pierce the rear bumper.

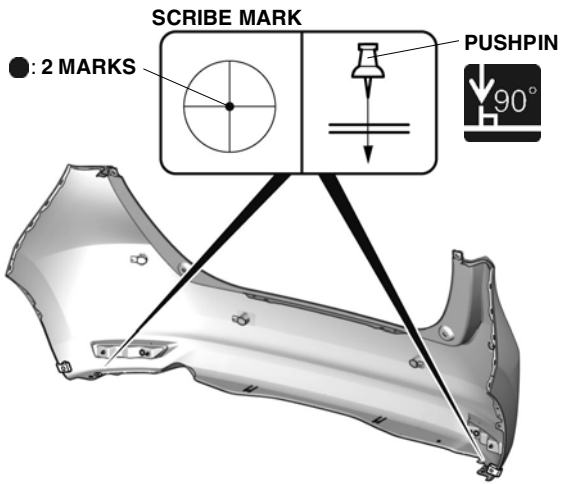

QJ40713BU

27. Drill the rear bumper.

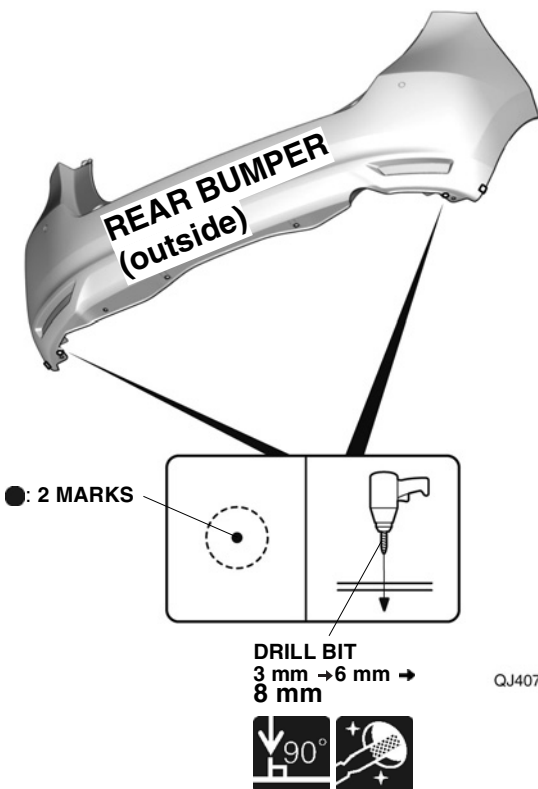

QJ40714BU

28. Install the spring nuts B.

NOTICE

- Make sure to install the spring nuts in the correct orientation.

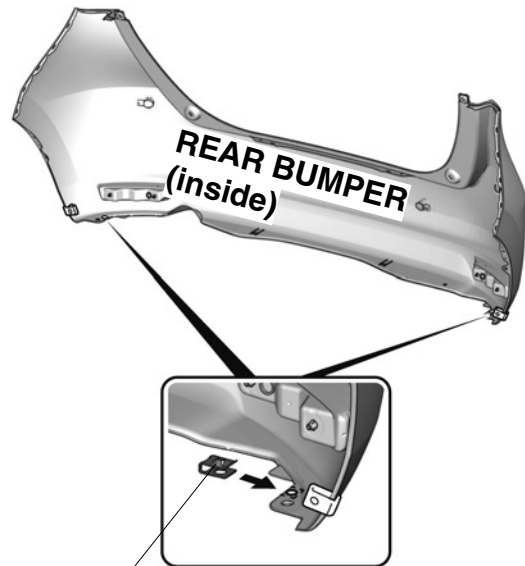

QJ40715BU

29. Reinstall the rear bumper.

30. Remove the tapes attached in step 25.

31. Install the left rear mud guard.

NOTICE

- Make sure that there is no gap between the mud guard and vehicle.
- Make sure that the mud guard is properly installed.

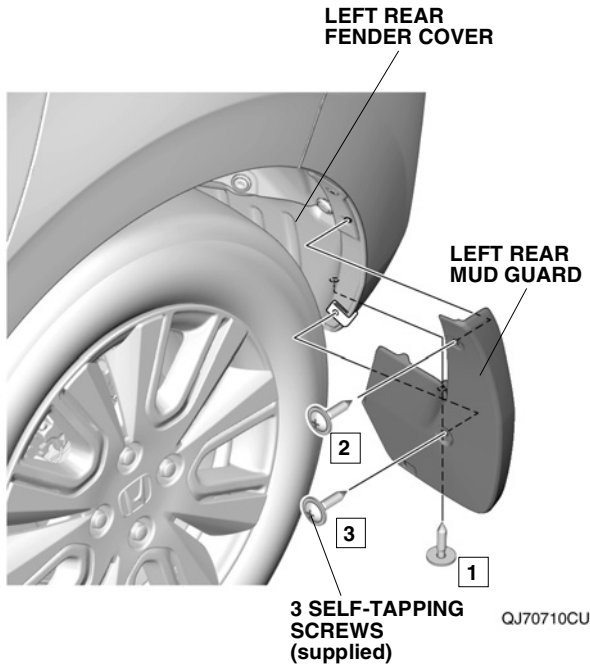
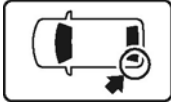

32. Repeat step 31 for the other side.

Check After Installation

33. Check that all parts are routed and installed properly.

NOTICE

- Check that the harnesses are not pushed, not pulled and not pinched.
- Check that all clamps and wire ties are installed securely.

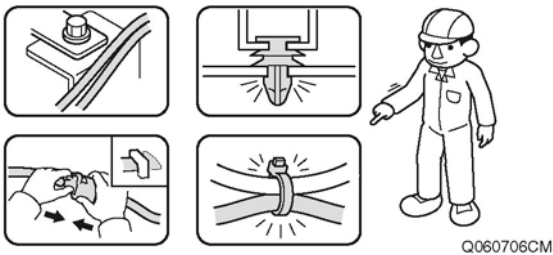

Vehicle Check

34. Reconnect the negative cable to the battery.
35. Check that the electric accessories and systems operate properly.
36. Press and hold the audio power button for two seconds, or enter anti-theft code for the audio/navigation system.
37. Reset the memory of each equipment and restore the positions of those control knobs.

