

REAR BUMPER PROTECTOR

*CIVIC*

### GENERAL VIEW

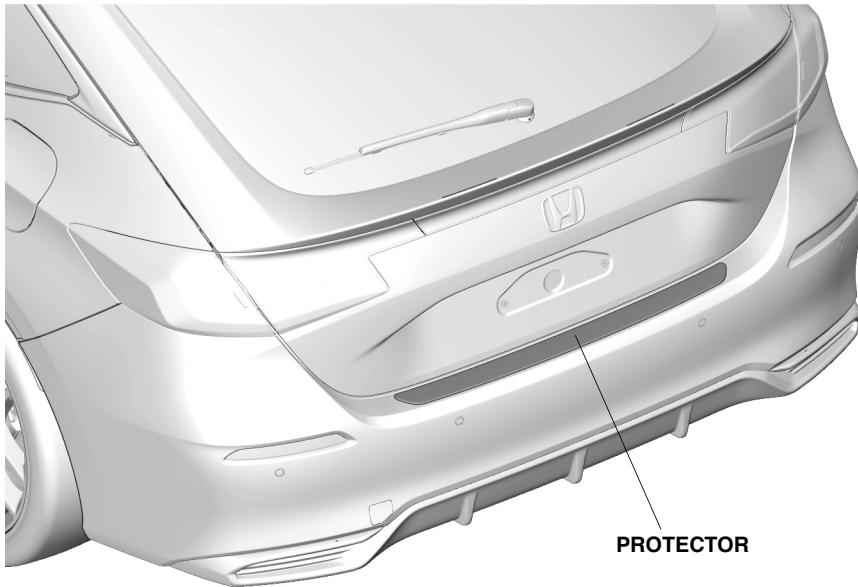

PROTECTOR

QL00601AH

### FOR YOUR SAFETY (Read carefully)

#### Introduction of Symbol Messages

- These symbols warn you about the possible hazards and explain how to avoid them. The symbols also provide you with some advice.

**⚠ DANGER**

You will be killed or seriously hurt if you do not follow the instructions.

**⚠ WARNING**

You may be killed or seriously hurt if you do not follow the instructions.

**⚠ CAUTION**

You may be hurt if you do not follow the instructions.

**NOTICE**

Gives advice to prevent damage to the product.

Gives helpful information or instructions to be followed in using the product.



Indicates prohibited actions.

## Introduction of Icons

- These icons indicate the working place and the worker's viewing angle.

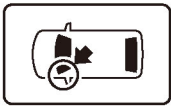

The place for the vehicle.

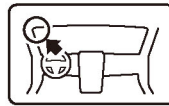

The place for the instrument panel.

- These icons indicate the necessary actions that need to be taken to ensure your safety and the success of the work.



Wear eye protection.



Wear heavy gloves.



Work with an assistant.



Place the part on a blanket.



Remove any burrs.



Use the touch-up paint and dry.



Keep the parts and give them to the customer. (Do not use)



Press firmly.



Tighten by the specified torque.



Work perpendicularly.



Clean with the contact cleaner.

## Safety: General

- Be careful not to damage the vehicle and the parts.
- The illustrations may differ a little from the actual accessories for the design change of the vehicle.

## Safety: For the Accessory

- **Do not carry out any installation or attachment work in an area that receives direct sunlight or in an area where dust is present.**
- **Always install these accessories at the ambient air temperature 15°C (60°F) or above.**
- **Heat the accessories and bonding surfaces if the ambient air temperature is below 15°C (60°F).**
- **Attach the accessories by pressing them firmly with the palm of your hand. Be careful not to damage the accessories and the vehicle parts.**
- **Carefully place the double-sided adhesive tape in the proper position. Once the double-sided adhesive tape touches the surface, do not try to detach and relocate the tape. If you attempt to move the tape after it comes into contact with the surface, you will damage the part before the adhesive can be detached.**
- **Do not wash the vehicle for 24 hours to allow the adhesive to cure.**

# PARTS LIST

## Protector Kit

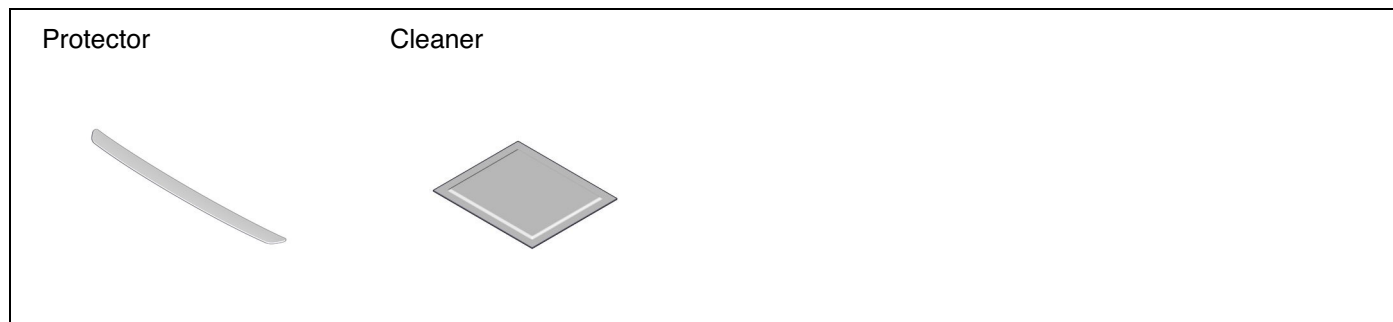

## TOOLS AND SUPPLIES REQUIRED

- Masking tape
- Felt-tip pen
- Ruler

# INSTALLATION

## Installing the Protector

1. Attach the masking tape.
2. Mark the masking tape.

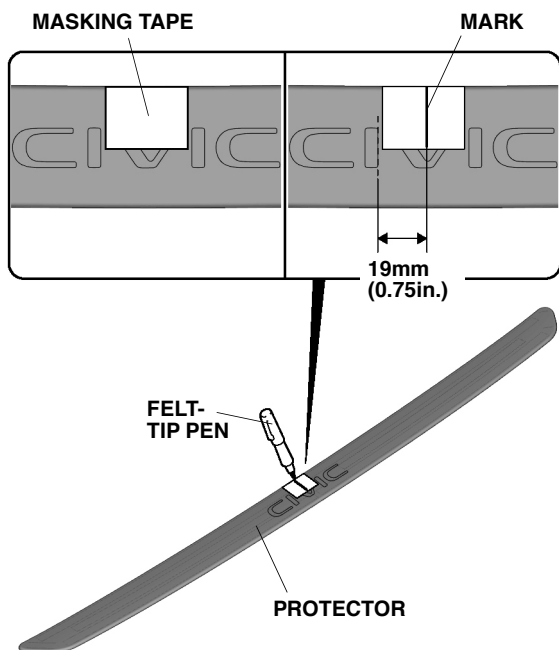

QL00602DH

3. Attach the masking tape.
4. Mark the masking tape.

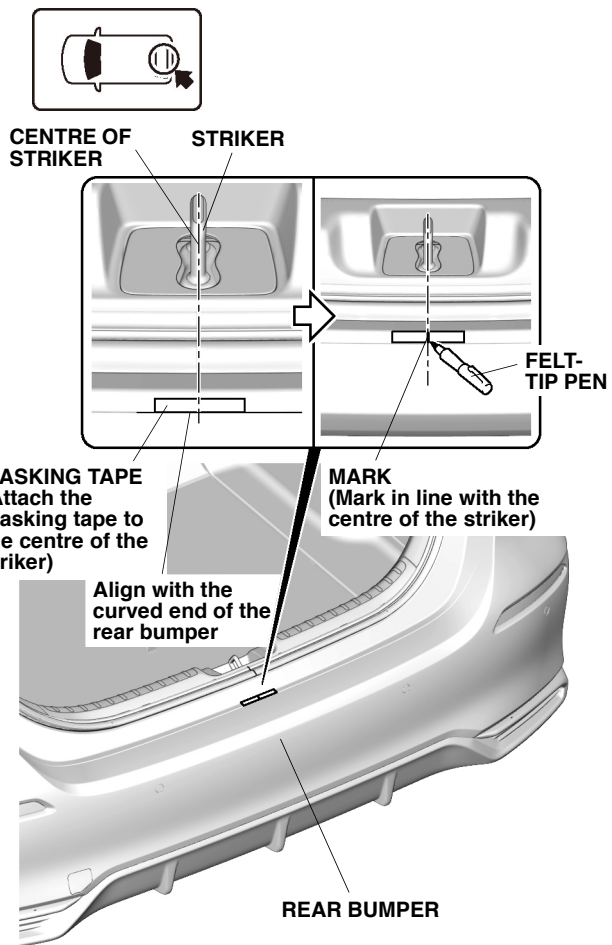

QL00603AH

5. Align the protector.
6. Loosely secure the protector.

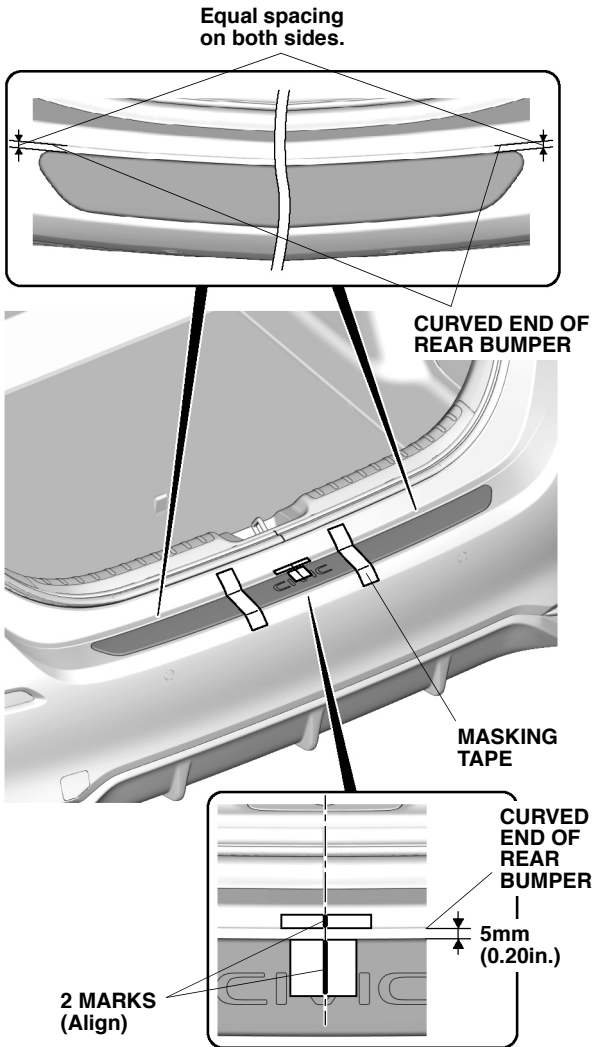

QL00609AH

7. Attach the masking tape.

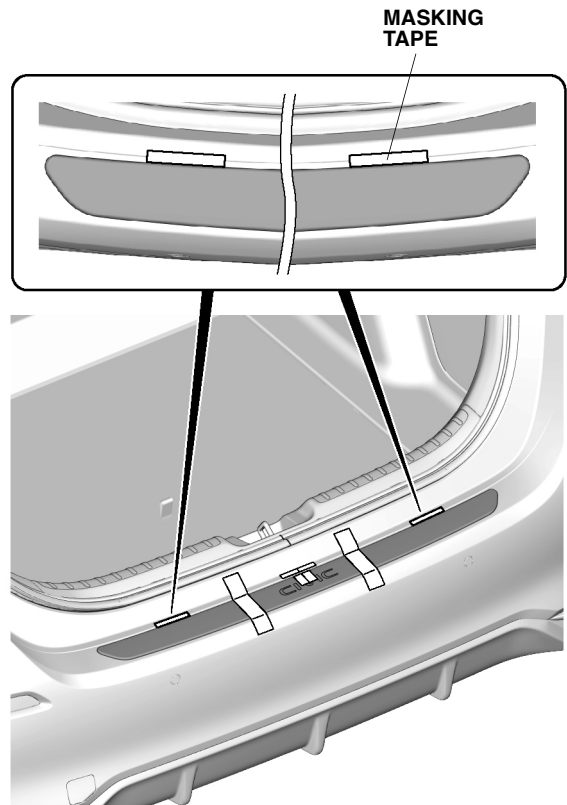

QL00610AH

8. Remove the protector.
9. Clean the rear bumper.

|                                                                              |
|------------------------------------------------------------------------------|
| <b>NOTICE</b>                                                                |
| <ul style="list-style-type: none"> <li>• Allow to dry thoroughly.</li> </ul> |

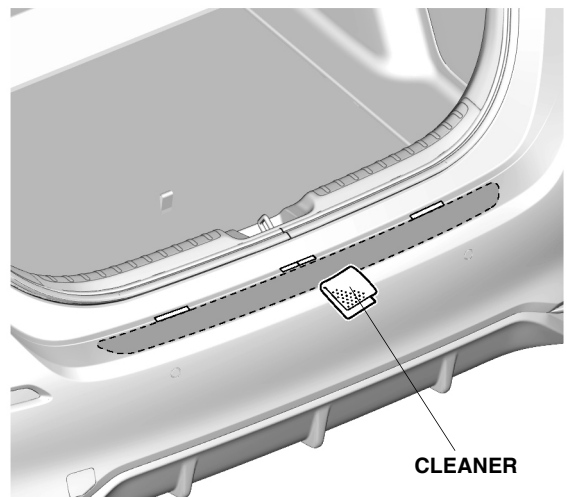

QL00605BH

10. Temporarily attach the adhesive backings.
11. Remove the adhesive backings.

**6 ADHESIVE BACKINGS**

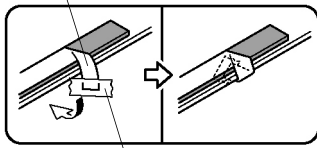

**MASKING TAPE**

**2 ADHESIVE BACKINGS**

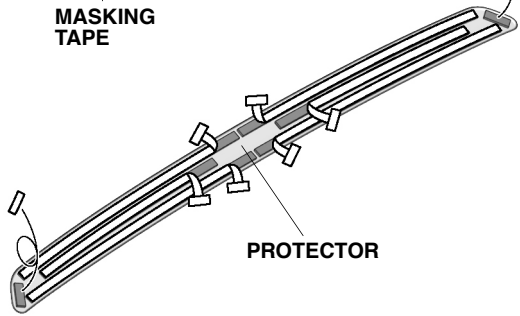

**PROTECTOR**

QL00606BH

12. Align the protector.

**Align.**

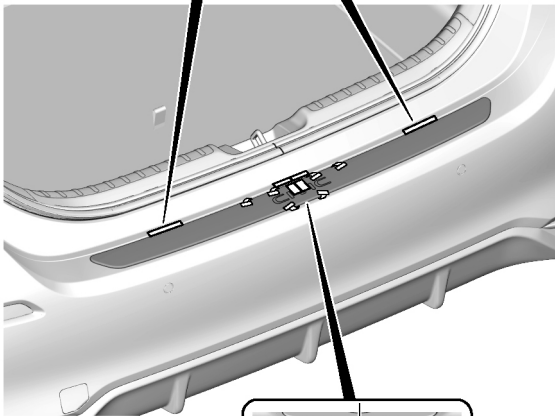
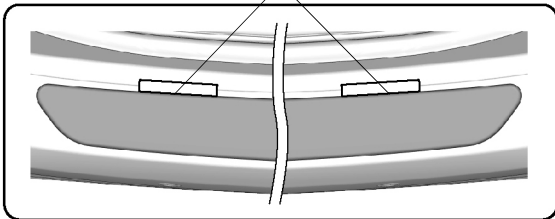

**2 MARKS (Align)**

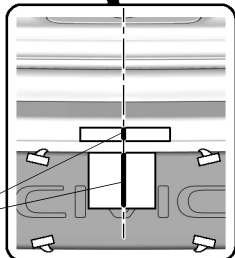

QL00607BH

13. Loosely secure the protector.

### NOTICE

- Install in the order shown.

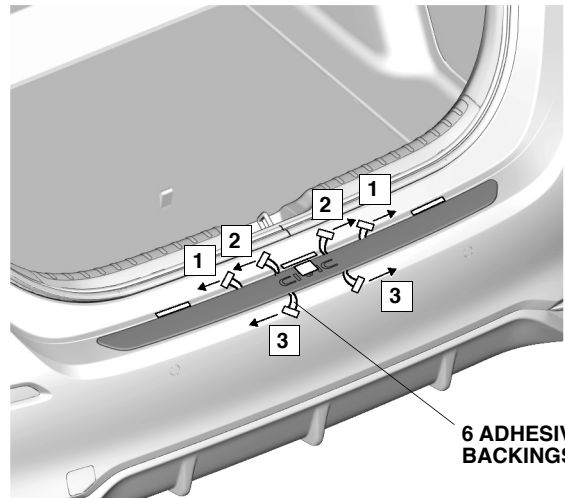

**6 ADHESIVE BACKINGS**

QL00608DH

14. Secure the protector.

### NOTICE

- Check the position of the double-sided adhesive tape and press until the vehicle body shakes (49N (5kgf) or more).

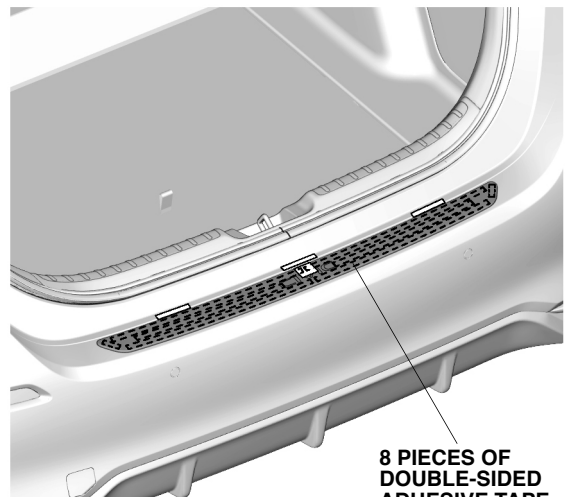

**8 PIECES OF DOUBLE-SIDED ADHESIVE TAPE**



QL00611AH

15. Remove the masking tape.
16. Remove the protective film if necessary.
17. Check that all parts are installed properly. (End of installation)