



# CROSSBARS

---

## OWNER'S MANUAL

# ENGLISH

Thank you for purchasing a Honda product.

Please read this Owner's Manual before using the Honda product and keep it in the glove box for future reference.

- This product is designed to be used exclusively with Honda vehicles. Honda is not responsible for the product installed in other than applicable Honda vehicles.  
For information on the applicable models, please contact your Honda dealer.
- The Owner's Manual should be considered a permanent part of your vehicle. It should remain with the vehicle at all times and stay with the vehicle if it is sold.

## SPECIAL MESSAGES

- Honda provides many important safety messages in this manual. For your safety and safety of others, pay special attention to all warnings preceded by this alert symbol .  
Failure to follow the warnings contained in this manual can result in serious injury or accident.



### DANGER

- Indicates that severe personal injury or death will result if instructions are not followed.



### WARNING

- Indicates a strong possibility that serious injury or death may result if instructions are not followed.



### CAUTION

- Indicates a possibility that minor personal injury may result if instructions are not followed.

## SYMBOLS

- If instructions are preceded by the following symbols, they will give helpful advice or information.



### ADVICE

- Gives advice to prevent damage to the product.
- Gives advice to handle emergency situation.



### INFORMATION

- Gives helpful information or instructions to be followed in using the product.

## SAFETY PRECAUTIONS



### WARNING

- **Overloading or improperly loading your vehicle can cause a crash in which you or other road users can be seriously hurt or killed.**
- **Always follow the weight limitations, installation instructions and loading guidance set forth in this manual.**



### ADVICE

- The maximum cargo weight capacity must not exceed 75 kg (165 lbs).  
**The crossbar can be loaded with up to three bicycles.**
- Before driving, make sure that all fastening parts are fixed according to regulations. Please check if the load is fastened properly. Stop after a short drive to check crossbar, then check every time before driving.
- Make sure to fasten load so that it cannot come loose or cause damage. Be careful to secure load against movement in driving direction or sideways movements. When loading the crossbar, make sure that the weight is evenly distributed and that the center of gravity of the load is kept as low as possible.
- For safety reasons, the load may not protrude from the vehicle outline.
- Be careful when loading a long object, as it may interfere with opening the tailgate.
- Do not put the vehicle through an automatic vehicle wash when the crossbar is mounted.
- Sudden starts or stops can cause rattling or loosening of the crossbar. Drive at moderate speed.
- When the crossbar is installed, the vehicle height becomes higher. Pay attention not to hit the crossbar while driving under bridges, tunnels, street trees, etc.
- Please pay attention to the altered behavior to the vehicle (due to side wind sensitivity, when driving in bends and when braking) when you drive a mounted (loaded) crossbar. To safeguard other road users, and in order to reduce air resistance, the crossbar should be dismounted if it is not used.
- When objects with large surfaces are transported, (e.g. surfboards, ski/transport boxes) the increased air resistance will create significant stress on the roof of the vehicle. (When transporting a surfboard, the nose should point downwards toward the front of the vehicle.) The driving characteristics change as well; therefore we recommend you to adjust your speed accordingly.
- Obey local laws and regulations.
- All wheel sizes and attachments may not be applicable depending on the sales area.

**KIT**

Front crossbar  
(identification mark:  
FRONT LEFT)



Rear crossbar  
(identification mark:  
REAR LEFT)



2 Moldings



8 Bolts



TORX wrench  
(T-30)

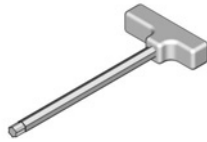

TORX wrench  
(T-20)



Storage bag

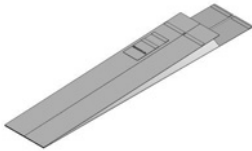

Owner's Manual

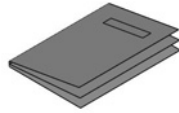

## INSTALLATION

1. Remove the eight covers from the left roof rail and right roof rail.

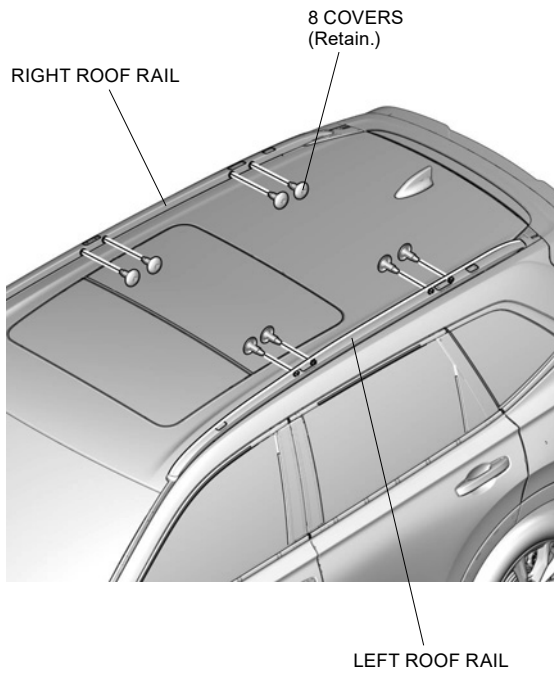

2. Remove the left inner cover and left outer cover from the front crossbar. Repeat the same procedure on the other side.



### ADVICE

- Make sure to check the identification mark before installation.

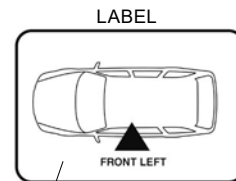
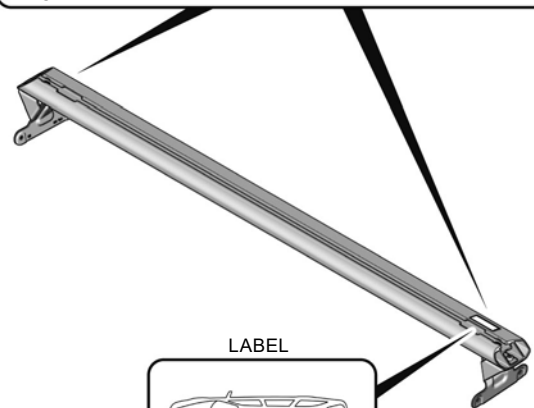
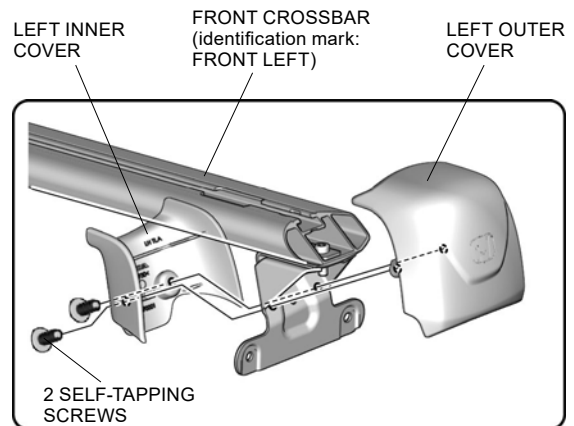

IDENTIFICATION MARK: FRONT LEFT

3. Loosen the four bolts on the front crossbar.
4. Position the front crossbar to the roof rails.



**ADVICE**

- Make sure to check the identification mark before installation.

FRONT CROSSBAR      4 BOLTS (Loosen.)      Adjust in or out.

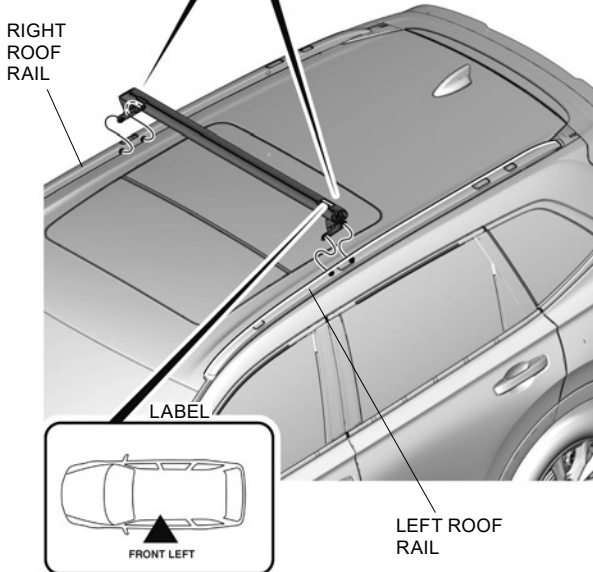
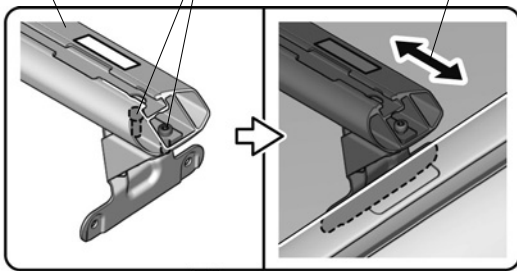

5. Place blankets to protect the vehicle.
6. Secure the front crossbar to the roof rails.



**ADVICE**

- Be extremely careful not to damage the roof.
- Torque the four bolts to 10 N·m (1.0 kgf·m, 7.4 lbf·ft)

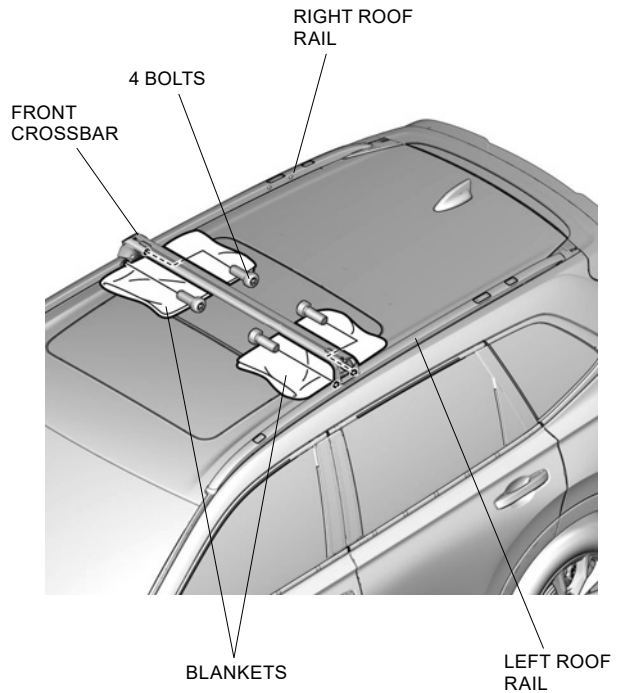

7. Tighten the four bolts on the front crossbar.



**ADVICE**

- Torque the four bolts to 5-7 N·m (0.5-0.7 kgf·m, 3.7-5.2 lbf·ft)

FRONT CROSSBAR  
4 BOLTS (Tighten.)

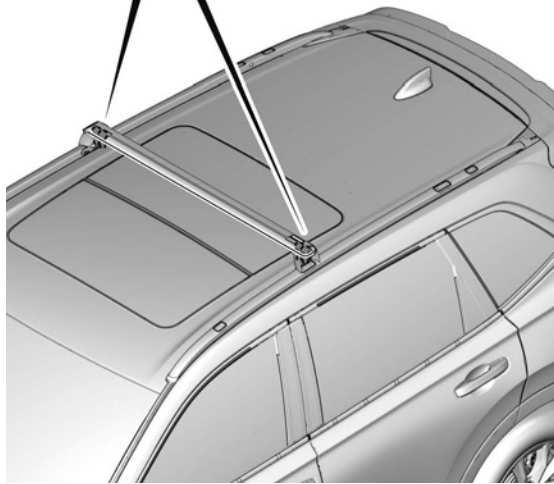
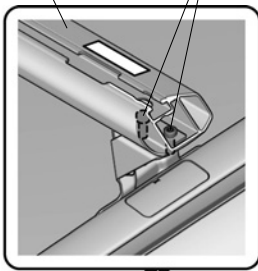

8. Install the molding to the front crossbar.



**ADVICE**

- Cut-off the excess molding if needed.

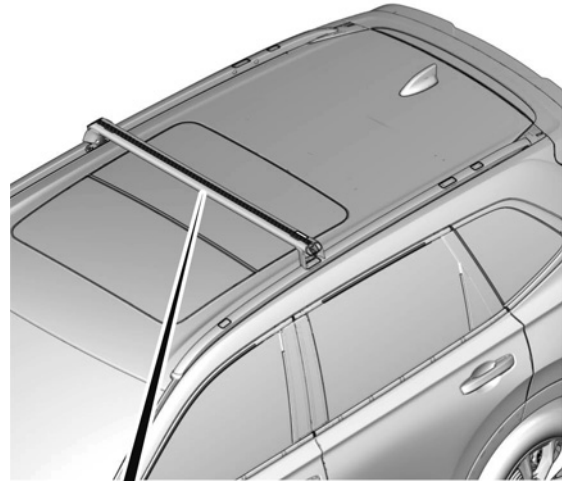

MOLDING

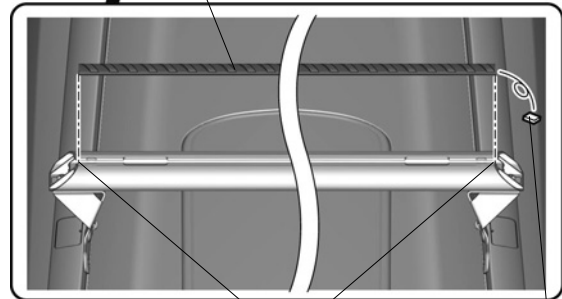

Align with the edges of the front crossbar.

Cut-off the excess molding if needed.

9. Reinstall the left inner cover and left outer cover to the front crossbar. Repeat the same procedure on the other side.



**ADVICE**

- Make sure to check the identification mark before installation.



FRONT CROSSBAR

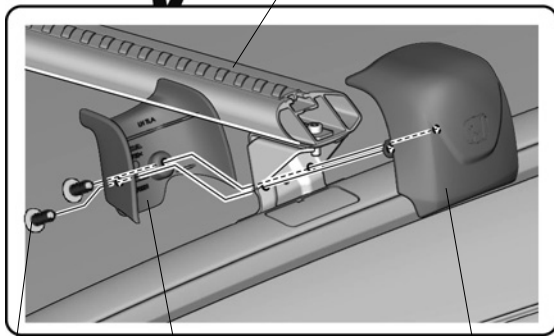

2 SELF-TAPPING SCREWS

LEFT INNER COVER (identification mark: LH)

LEFT OUTER COVER (identification mark: LH)

10. Repeat steps 2 through 9 on the rear crossbar.

11. Check the crossbars.



**ADVICE**

- Rock the crossbars in all directions to check if they are installed securely without play or rattle.
- If found with abnormal play or rattle, retighten the bolts, or reinstall the crossbars as described in these installation instructions.

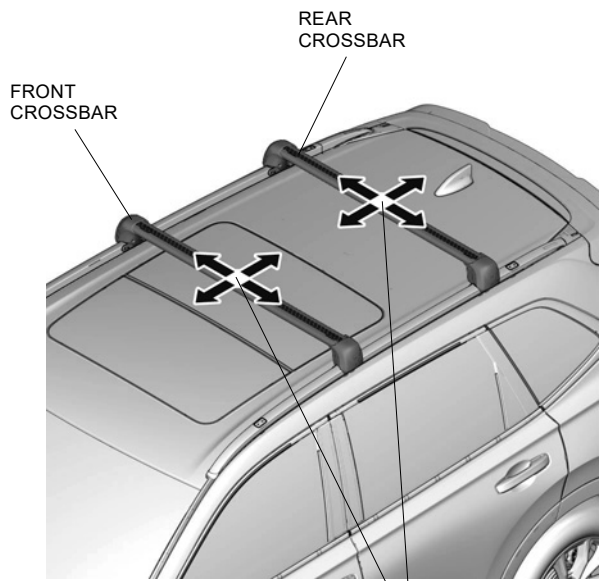

FRONT CROSSBAR

REAR CROSSBAR

Check for play or rattle by rocking in all directions.

12. Check that all parts are installed properly. (End of installation)

**HOW TO REMOVE THE CROSSBARS**

- Remove the four bolts installed in step 6, and remove the front crossbar. Repeat the same procedures on the rear crossbar.