

RUNNING BOARDS

ZR-V

GENERAL VIEW

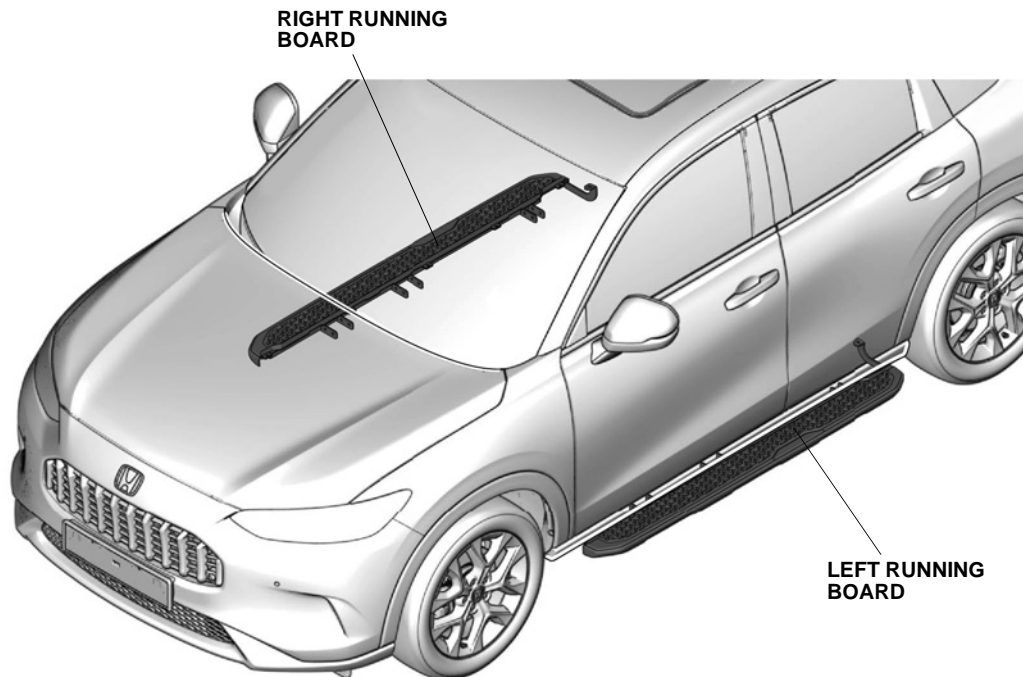

QM81001AN

FOR YOUR SAFETY (Read carefully)

Introduction of Symbol Messages

- These symbols warn you about the possible hazards and explain how to avoid them. And give you some advices.

⚠ DANGER

You will be killed or seriously hurt if you do not follow the instructions.

⚠ WARNING

You can be killed or seriously hurt if you do not follow the instructions.

⚠ CAUTION

You can be hurt if you do not follow the instructions.

NOTICE

Gives advice to prevent damage to the product.
Gives helpful information or instructions to be followed in using the product.



Indicates prohibited actions.

Introduction of Icons

- These icons indicate the working place and the worker's vision.

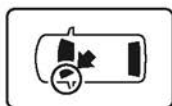

The place for the vehicle.

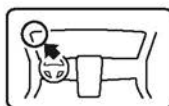

The place for the instrument panel.

- These icons indicate the necessary things for your safety and the work.



Wear eye protection.



Wear heavy gloves.



Work with an assistant.



Place the part on a blanket.



Remove any burrs.



Use the touch-up paint and dry.



Keep the parts and give it to the customer.
(Not use)



Press firmly.



Tighten by specified torque.



Work perpendicularly.



Clean with the contact cleaner.

Safety: General

- Observe all safety notes and precautions described in the Shop Manual in addition to those described in this Installation Instructions. Be extremely careful for your safety and safety of others particularly.
- Be careful not to damage the vehicle and the parts.
- Be extremely careful to the handling of the retaining tabs and clips particularly.
- Note the locations of the parts before removing them so that they can be reinstalled in their original positions properly.
- The illustrations may differ a little from the actual accessories for the design change of the vehicle.

Safety: For the Accessory

- **Always use the parts and tools specified in the installation instructions.**

PARTS LIST

Running Boards Kit

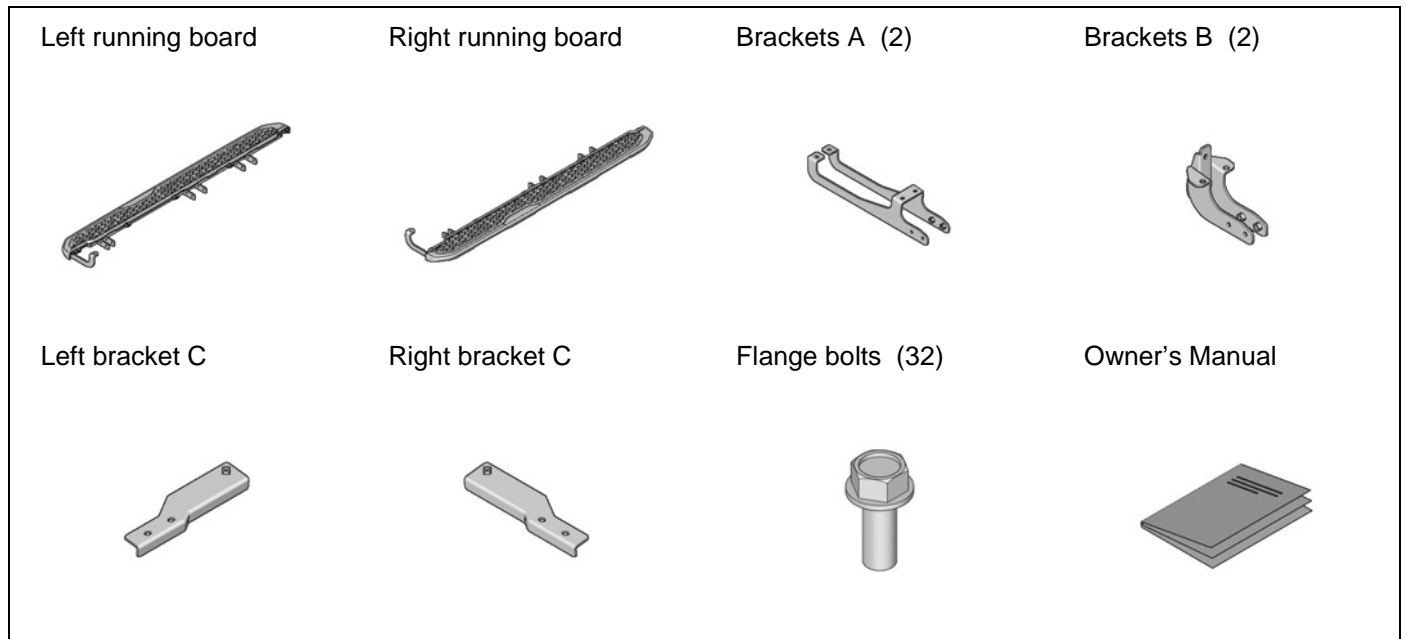

TOOLS AND SUPPLIES REQUIRED

- Handy remover
- Torque wrench
- Shop towel
- Felt-tip pen
- Ratchet
- Utility knife
- Contact cleaner
- File
- 10 mm and 12 mm Sockets
- Touch-up paint
- Masking tape

INSTALLATION

Removing the Vehicle Parts

1. Lift up the vehicle.
2. Remove the floor under cover.



ENGINE UNDER COVER

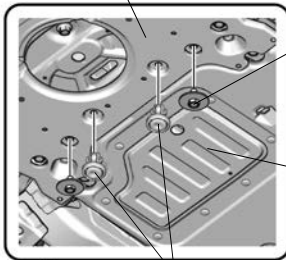

2 WASHER-BOLTS

N·m 6.9-11.8 N·m
(0.8-1.2 kgf·m,
5.1-8 lbf·ft)

FLOOR UNDER COVER

FLANGE NUT

N·m 6.9-11.8 N·m
(0.8-1.2 kgf·m,
5.1-8 lbf·ft)

2 CLIPS
(long)

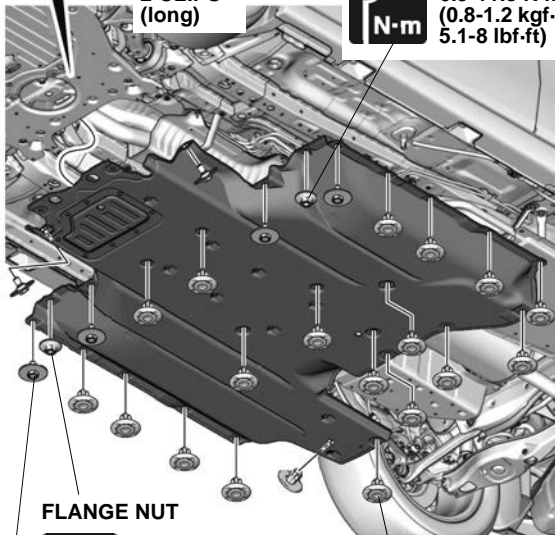

FLANGE NUT

N·m 6.9-11.8 N·m
(0.8-1.2 kgf·m,
5.1-8 lbf·ft)

19 CLIPS

QM81002AN

6 WASHER-BOLTS

N·m 6.9-11.8 N·m
(0.8-1.2 kgf·m,
5.1-8 lbf·ft)

Installing the Running Boards

3. Remove the undercoat.

NOTICE

- Be careful not to damage the vehicle panel by filing off the undercoat excessively.

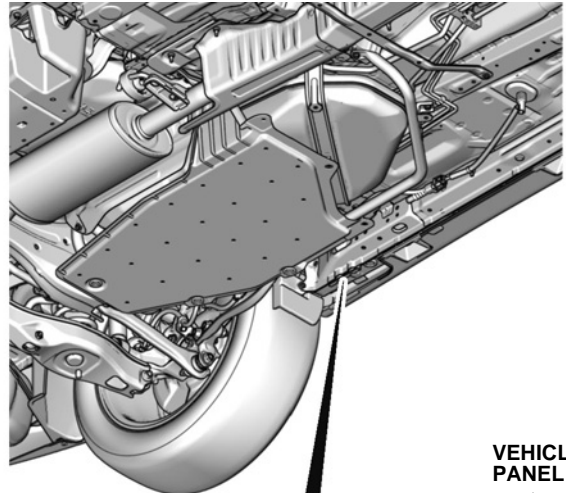
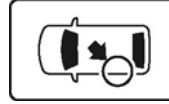

VEHICLE PANEL

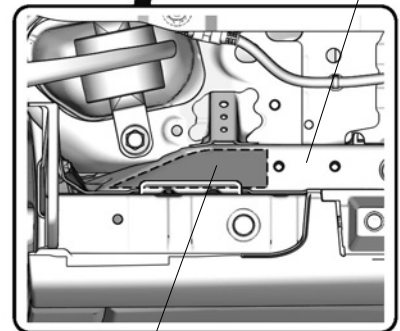

UNDERCOAT
(Remove.)

QM40805AA



4. Repeat step 3 on the other side.

5. Mark the floor under cover.

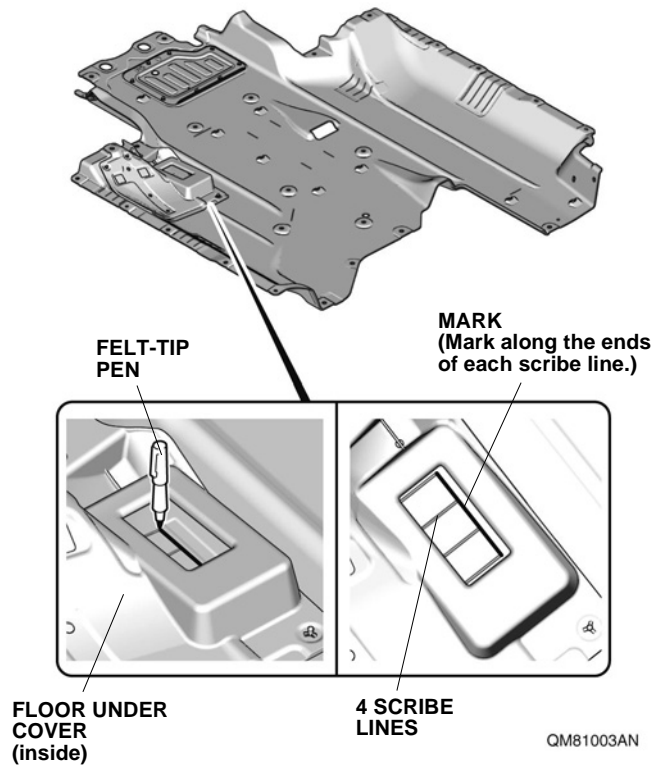

6. Cut the floor under cover.

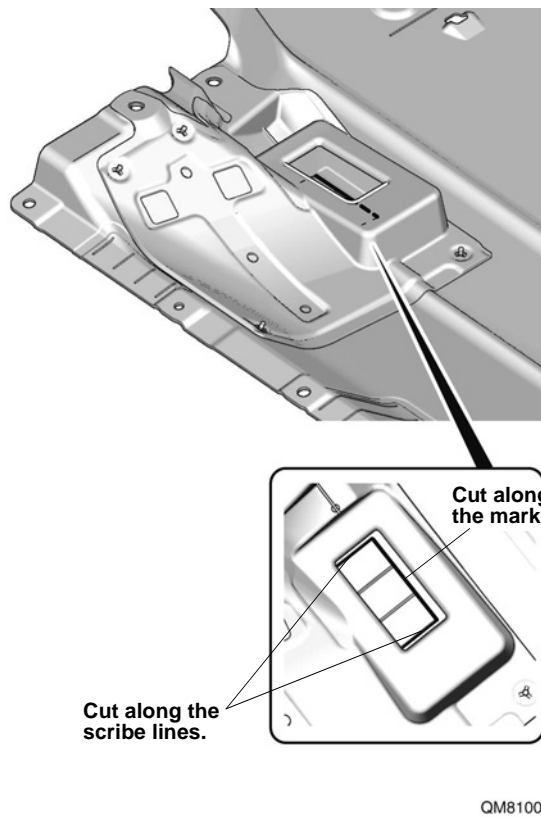

7. Attach the masking tapes.

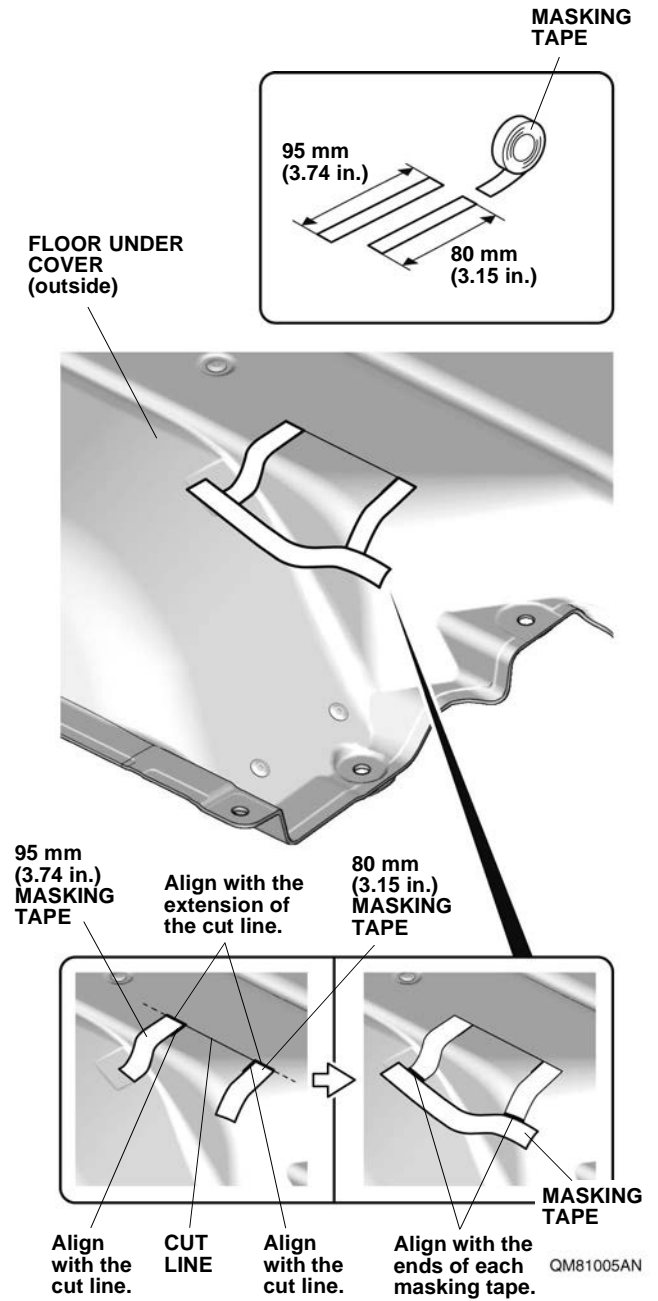

8. Mark the floor under cover.

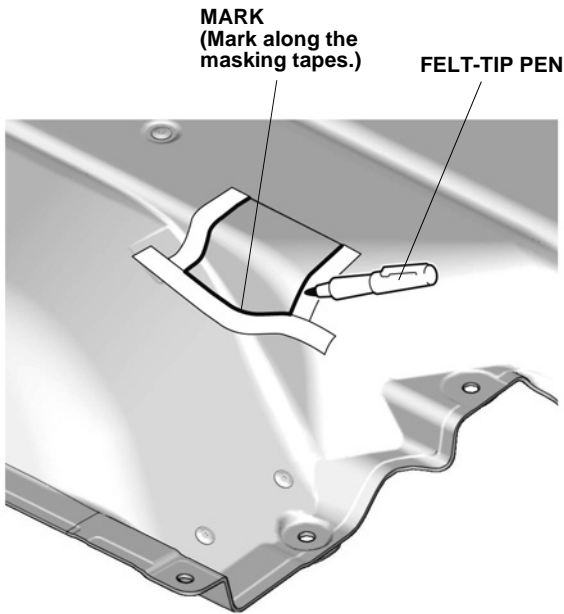

QM81006AN

- 9. Remove the masking tapes.
- 10. Cut the floor under cover.

NOTICE

- Be careful not to damage the inside parts.

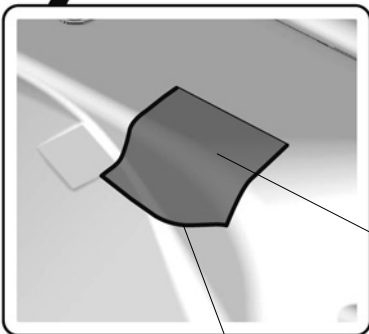
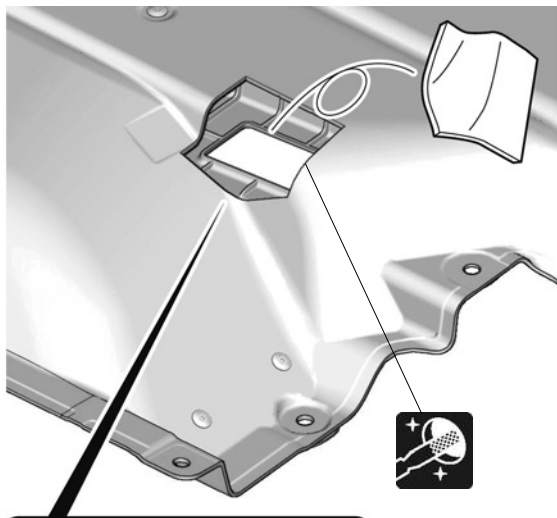

Cut along the mark.

QM81007AN

11. Mark the floor under cover.

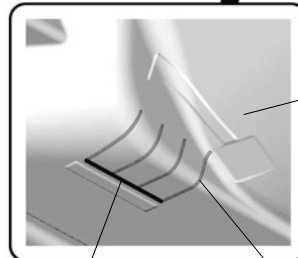
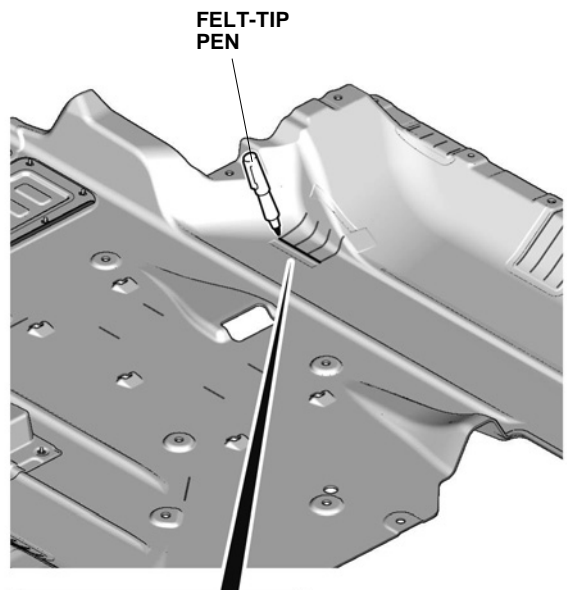

MARK (Mark along the ends of each scribe line.)

4 SCRIBE LINES

QM81008AN

12. Attach the masking tapes.

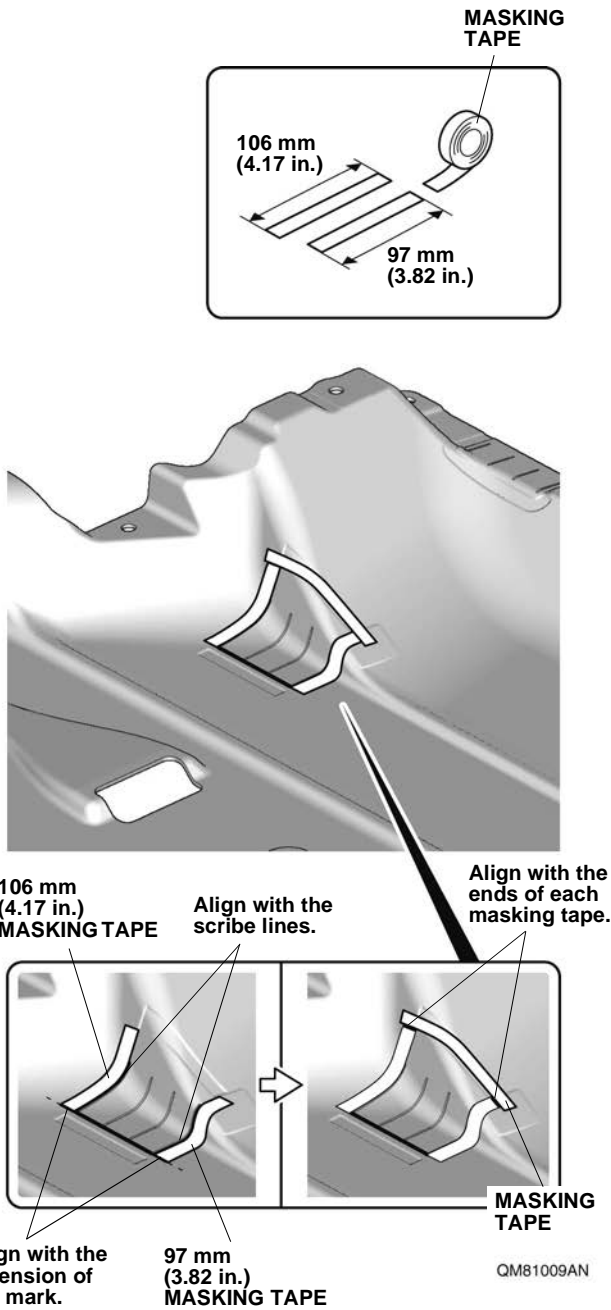

13. Mark the floor under cover.

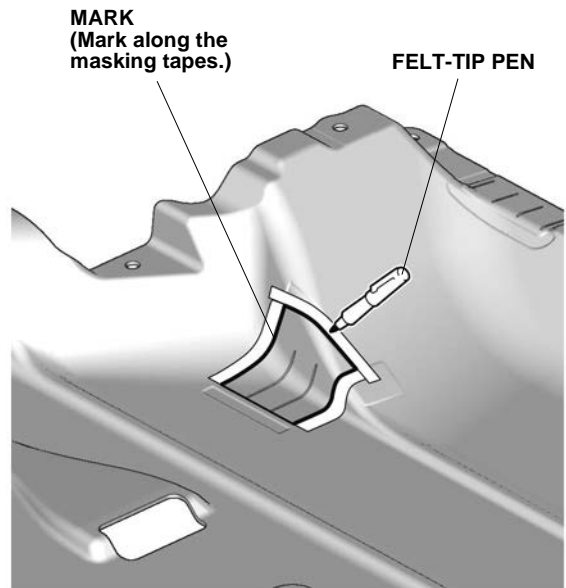

QM81010AN

14. Remove the masking tapes.

15. Cut the floor under cover.

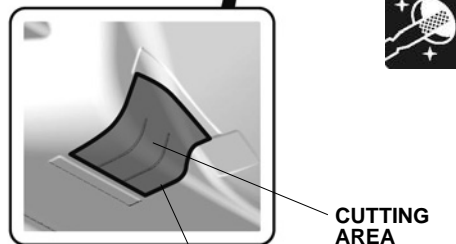
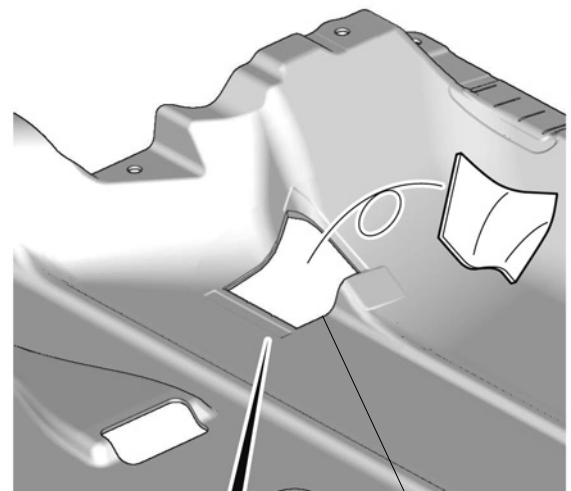

Cut along the mark.

QM81011AN

16. Cut the floor under cover.

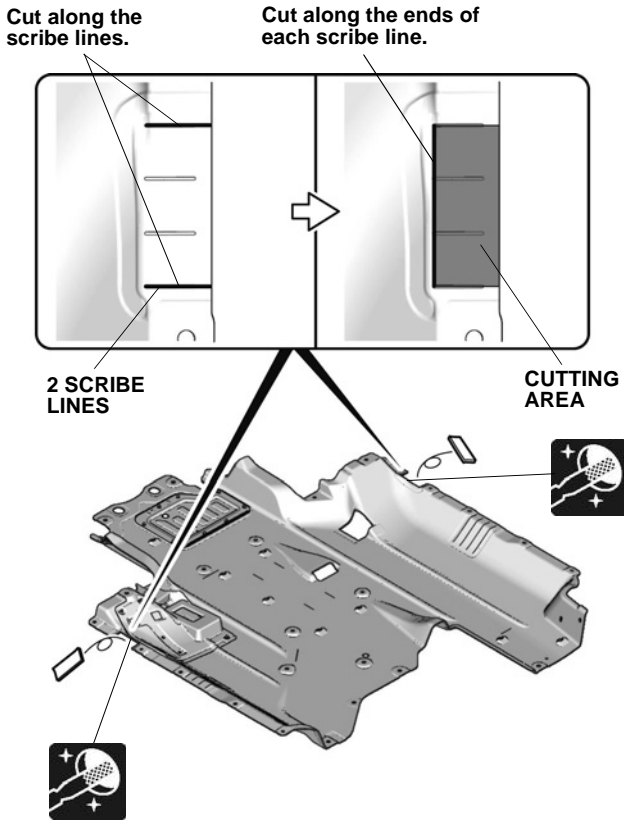

17. Reinstall the floor under cover.

18. Loosely install the bracket A.

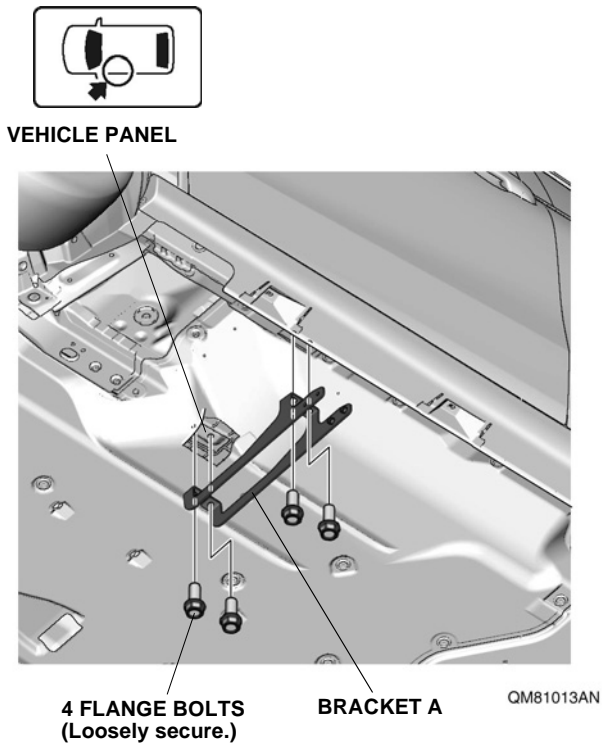

19. Loosely install the bracket B and left bracket C.

NOTICE

- Make sure to check the shape before installation.

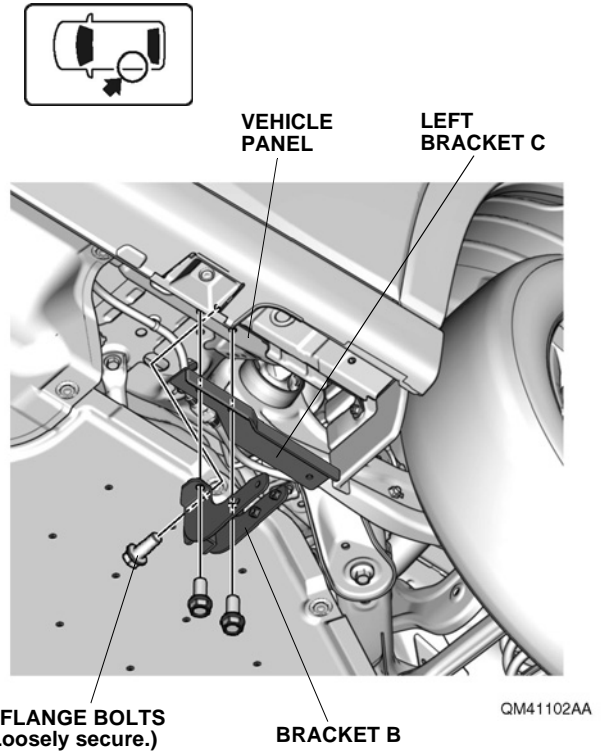

20. Loosely install the left running board.

NOTICE

- Install in the order shown.

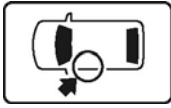

BRACKET A LEFT RUNNING BOARD BRACKET B LEFT BRACKET C

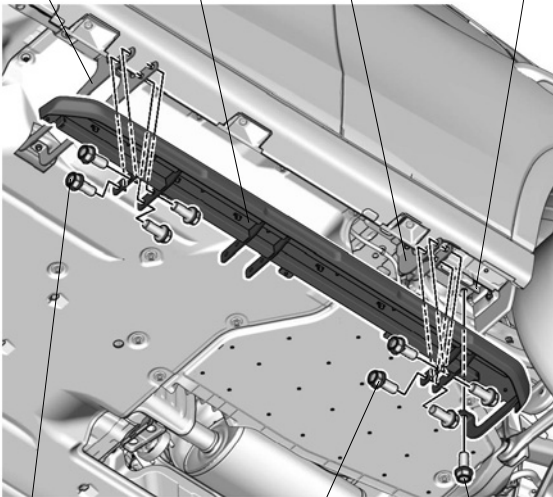

- 1 4 FLANGE BOLTS (Loosely secure.)
 - 1 4 FLANGE BOLTS (Loosely secure.)
 - 2 FLANGE BOLT (Loosely secure.)
- QM41103AA

21. Secure the bracket A, bracket B, and left bracket C.

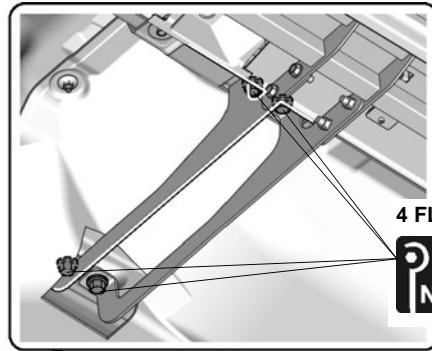

4 FLANGE BOLTS
22 N·m
 (2.2 kgf·m,
 16 lbf·ft)

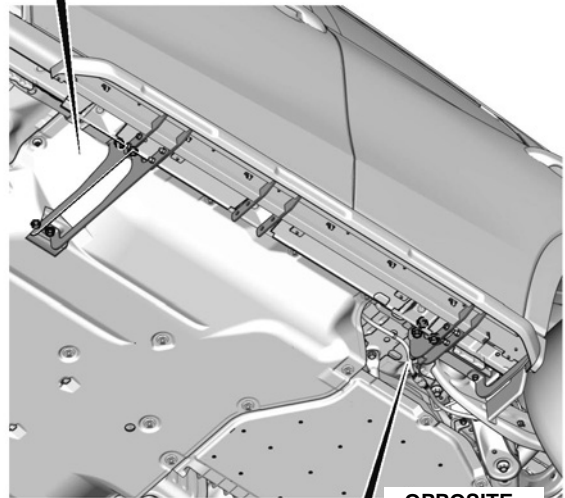

<OPPOSITE SIDE VIEW>

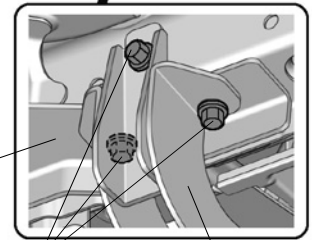

LEFT BRACKET C

3 FLANGE BOLTS
22 N·m
 (2.2 kgf·m,
 16 lbf·ft)

QM41104AA
 BRACKET B

22. Secure the left running board.

8 FLANGE BOLTS

N·m
22 N·m
(2.2 kgf·m,
16 lbf·ft)

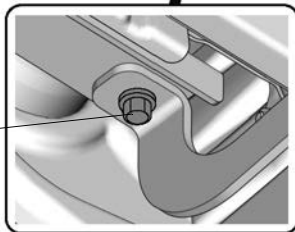
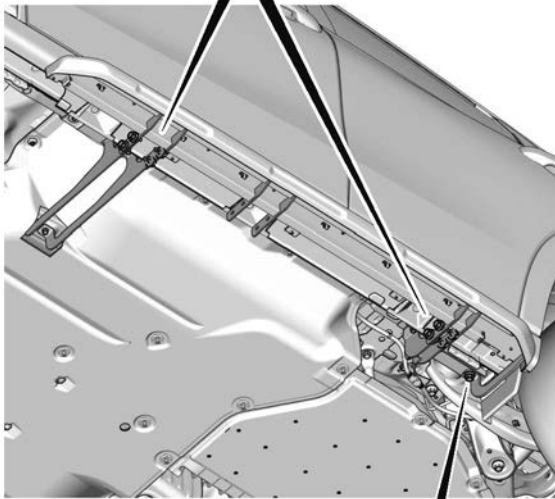
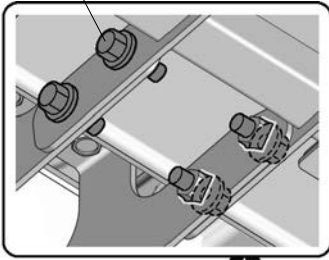

FLANGE BOLT

N·m
22 N·m
(2.2 kgf·m,
16 lbf·ft)

QM41105AA

23. Repeat the same procedures on the other side.

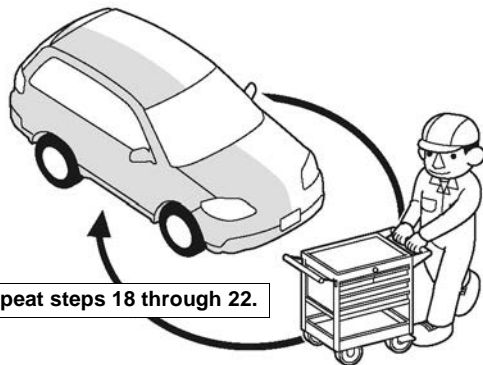

Repeat steps 18 through 22.

Q9D1014AM

Check After Installation

24. Check that all parts are routed and installed properly.

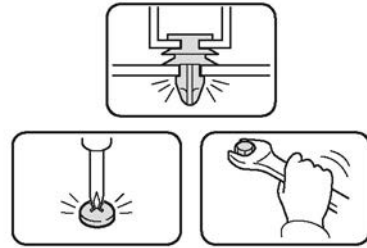

Q060705CM

Please pass your customer the following things.

- Owner's Manual